

CLASSIC
Professional +
t o l e d o
90 Induction



User Guide
&
Installation Instructions



U110100 - 01

Australia

Contents

1. Before You Start...	1	6. Troubleshooting	19
Installation and Maintenance	1	7. Installation	22
Peculiar smells	1	Service and Spares	22
Ventilation	1	Dear Installer	23
Personal Safety	1	Safety Requirements	23
Hob Care	3	Provision of Ventilation	23
Cooker Care	3	Location of Cooker	23
Cleaning	3	Positioning the Cooker	24
2. Cooker Overview	4	Moving the Cooker	25
The Hob	4	Completing the Move	25
The Grill / Glide-out Grill	7	Levelling	25
The Ovens	7	Electrical Connection	26
The Clock	8	Repositioning the Cooker following Connection	27
Accessories	12	Hob Check	27
Main Oven Light	12	Grill Check	27
3. Cooking Tips	13	Oven Check	27
Using your Induction Cooker	13	Fitting the Handles and Handrail (<i>Classic model only</i>)	27
Tips on Cooking with the Timer	13	Fitting the Plinth	28
General Oven Tips	13	Fitting the Splashback (<i>Classic model only</i>)	28
4. Cooking Table	14	Customer Care	28
5. Cleaning Your Cooker	15	8. Servicing	29
Hob	15	9. Circuit Diagrams	34
Grills	16	Circuit Diagram: Hob	34
Control Panel and Doors	16	Circuit Diagram: Fan Oven	35
Ovens	16	10. Technical Data	36
Glass Door Panels (<i>some models</i>)	17		
The Tall Oven	17		
Cleaning Table	18		

1. Before You Start...

This User Guide covers a 3 different models. Although some of the illustrations will look different to your particular model the functions will be the same. We hope the meaning is clear.

Your cooker should give you many years of trouble-free cooking if installed and operated correctly. It is important that you read this section before you start, particularly if you have not used an induction cooker before.

⚠ This appliance is designed for domestic cooking only. Using it for any other purpose could invalidate any warranty or liability claim. In particular, the oven should NOT be used for heating the kitchen – besides invalidating claims this wastes fuel and may overheat the control knobs.

Installation and Maintenance

The electrical installation must be in accordance with the relevant instructions in this booklet, with the relevant national and local regulations, and with the local electricity supply companies' requirements.

Make sure that the cooker is correctly wired and switched on.

The hob control display will flash for about 2 seconds during first power setting – this is normal.

Set the clock to ensure that the ovens are functional – see the relevant section in this manual.

Only a qualified service engineer should service the cooker, and only approved spare parts should be used.

Always allow the cooker to cool and then switch it off at the mains before cleaning or carrying out any maintenance work, unless specified otherwise in this guide.

Peculiar smells

When you first use your cooker it may give off a slight odour. This should stop after a little use.

Before using for the first time, make sure that all packing materials have been removed and then, to dispel manufacturing odours, turn the ovens to 200 °C and run for an hour.

Before using the grill for the first time you should also turn on the grill and run for 30 minutes with the grill pan in position, pushed fully back, and the grill door open.

Make sure the room is well ventilated to the outside air (see 'Ventilation' below). People with respiratory or allergy problems should vacate the area for this brief period.

Ventilation

The use of a cooking appliance results in the production of heat and moisture in the room in which it is installed. Therefore, ensure that the kitchen is well ventilated: keep natural ventilation holes open or install a powered cooker hood that vents outside. If you have several hotplates on, or use the cooker for a long time, open a window or turn on an extractor fan.

Personal Safety

Important information for pacemaker and implanted insulin pump users: The functions of this hob comply with the applicable local standards on electromagnetic interference. If you are fitted with a pacemaker or implanted insulin pump and are concerned please consult your doctor for medical advice.

- ⚠ When the hob is in use keep magnetic items, such as credit and debit cards, floppy disk, calculators, etc. away.**
- ⚠ DO NOT modify this appliance.**
- ⚠ This appliance is not intended for use by persons (including children) with reduced physical, sensory or mental capabilities, or lack of experience and knowledge, unless they have been given supervision or instruction concerning use of the appliance by a person responsible for their safety.**
- ⚠ This appliance is not intended for use by young children or infirm persons unless they have been adequately supervised by a responsible person to ensure that they can use the appliance safely.**
- ⚠ DO NOT use a steam cleaner to clean the cooker.**
- ⚠ Accessible parts will become hot during use and will retain heat even after you have stopped cooking. Keep babies and children away from the cooker and never wear loose-fitting or hanging clothes while the appliance is in use.**

Always be certain that the controls are in the OFF position when the oven is not in use, and before attempting to clean the cooker.

- ⚠ Take care when touching the marked cooking areas of the hob.**
- ⚠ When the oven is on, DO NOT leave the oven door open for longer than necessary, otherwise the control knobs may become very hot.**
- ⚠ When using the grill, make sure that the grill pan is in position and pushed fully in, otherwise the control knobs may become very hot.**

Fig.1-1

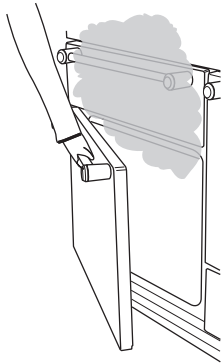

Always keep combustible materials, e.g. curtains, and flammable liquids a safe distance away from your cooker.

⚠ DO NOT spray aerosols in the vicinity of the cooker while it is on.

Cooking high moisture content foods can create a 'steam burst' when an oven door is opened (**Fig.1-1**). When opening an oven stand well back and allow any steam to disperse.

Use dry oven gloves when applicable – using damp gloves might result in steam burns when you touch a hot surface. Do not use a towel or other bulky cloth in place of a glove – it might catch fire if brought into contact with a hot surface.

⚠ NEVER operate the cooker with wet hands.

⚠ DO NOT use aluminium foil to cover shelves, linings or the oven roof.

⚠ NEVER heat unopened food containers. Pressure build up may make the containers burst and cause injury.

⚠ DO NOT use unstable saucepans. Always ensure that you position the handles away from the edge of the hotplate.

Never leave the hotplate unattended at high heat settings. Pans boiling over can cause smoking, and greasy spills may catch on fire. Use a deep fat thermometer whenever possible to prevent fat overheating beyond the smoking point.

⚠ NEVER leave a chip pan unattended. Always heat fat slowly, and watch as it heats. Deep fry pans should be only one third full of fat. Filling the pan too full of fat can cause spill over when food is added. If you use a combination of oils or fats in frying, stir them together before heating, or as the fats melt.

Foods for frying should be as dry as possible. Frost on frozen foods or moisture on fresh foods can cause hot fat to bubble up and over the sides of the pan. Carefully watch for spills or overheating of foods when frying at high or medium high temperatures. Never try to move a pan of hot fat, especially a deep fat fryer. Wait until the fat is cool.

Do not use the top of the flue (the slot along the back of the cooker) for warming plates, dishes, drying tea towels or softening butter.

⚠ DO NOT use water on grease fires and never pick up a flaming pan. Turn off the controls and then smother a flaming pan on a surface unit by covering the pan completely with a well fitting lid or baking tray. If available, use a multipurpose dry chemical or foam-type fire extinguisher.

Take care that no water seeps into the appliance.

⚠ This appliance is heavy so take care when moving it.

⚠ NEVER allow anyone to climb or stand on the hob.

Hob Care

⚠ DO NOT use the hob surface as a cutting board.

Do not leave utensils, foodstuffs or combustible items on the hob when it is not in use (e.g. tea towels, frying pans containing oil).

⚠ DO NOT place plastic or aluminium foil, or plastic containers, on the hob.

⚠ DO NOT leave the hob zones switched on unless being used for cooking.

Do not stand or rest heavy objects on the hob. Although the ceramic surface is very strong, a sharp blow or sharp falling object (e.g. a salt cellar) might cause the surface to crack or break (Fig.1-2).

⚠ Should a crack appear in the surface, disconnect the appliance immediately from the supply and arrange for its repair.

Always LIFT pans off the hob. Sliding pans may cause marks and scratches (Fig.1-3). Always turn the control to the OFF position before removing a pan.

DO NOT place anything between the base of the pan and the hob surface (e.g. asbestos mats, aluminium foil, wok stand).

Cooker Care

As steam can condense to water droplets on the cool outer trim of the oven, it may be necessary during cooking to wipe away any moisture with a soft cloth. This will also help to prevent soiling and discolouration of the oven exterior by cooking vapours (Fig.1-4).

Cleaning

DO NOT use abrasive cleaners/pads, oven aerosols/pads or stain removers on the surface.

In the interests of hygiene and safety, the cooker should be kept clean at all times as a build up in fats and other food stuff could result in a fire.

Clean only the parts listed in this guide.

We recommend that you avoid wiping any surface unit areas until they have cooled and the indicator light has gone off. Sugar spills are the exception to this (see 'Cleaning your Cooker'). After cleaning, use a dry cloth or paper towel to remove any cleaning cream residue.

The ceramic surface should be washed after use in order to prevent it from becoming scratched or dirty.

⚠ Caution! if a wet sponge or cloth is used to wipe spills on a hot surface, be careful to avoid steam burns.

⚠ Clean the hob with caution as some cleaners can produce noxious fumes if applied to a hot surface.

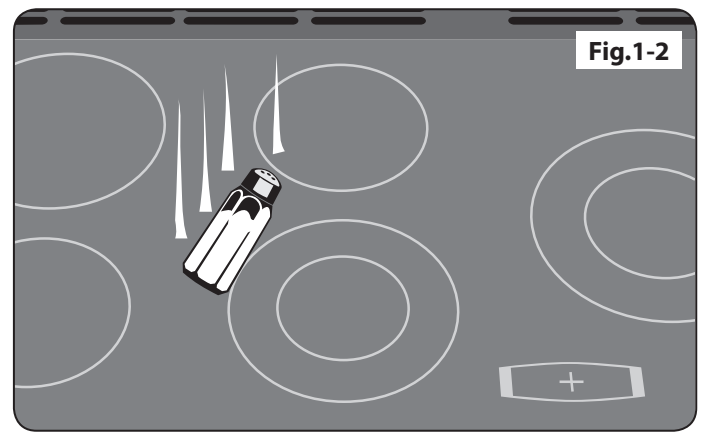

Fig.1-2

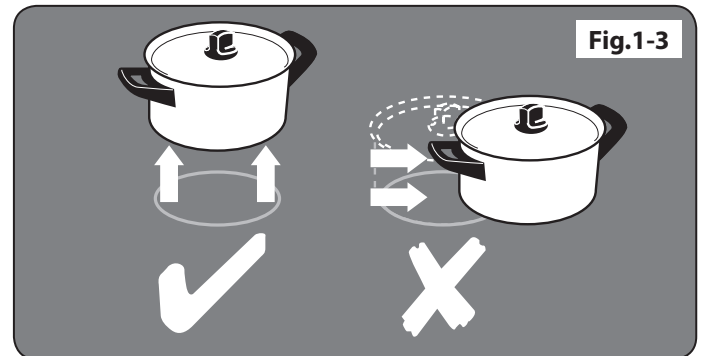

Fig.1-3

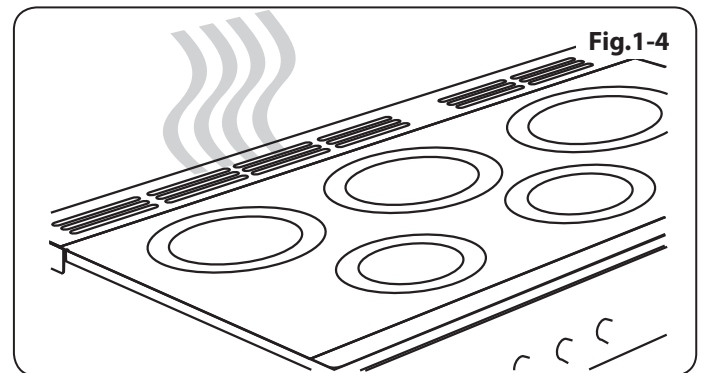
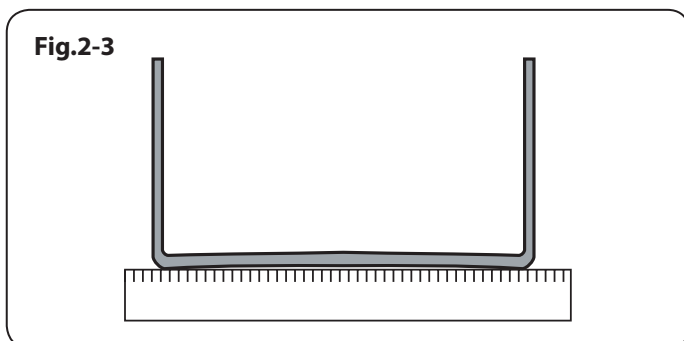
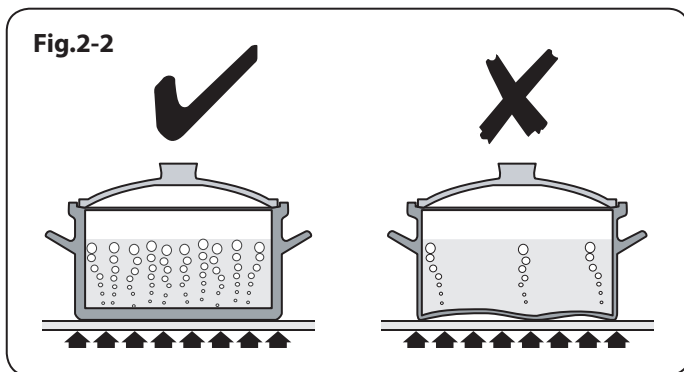
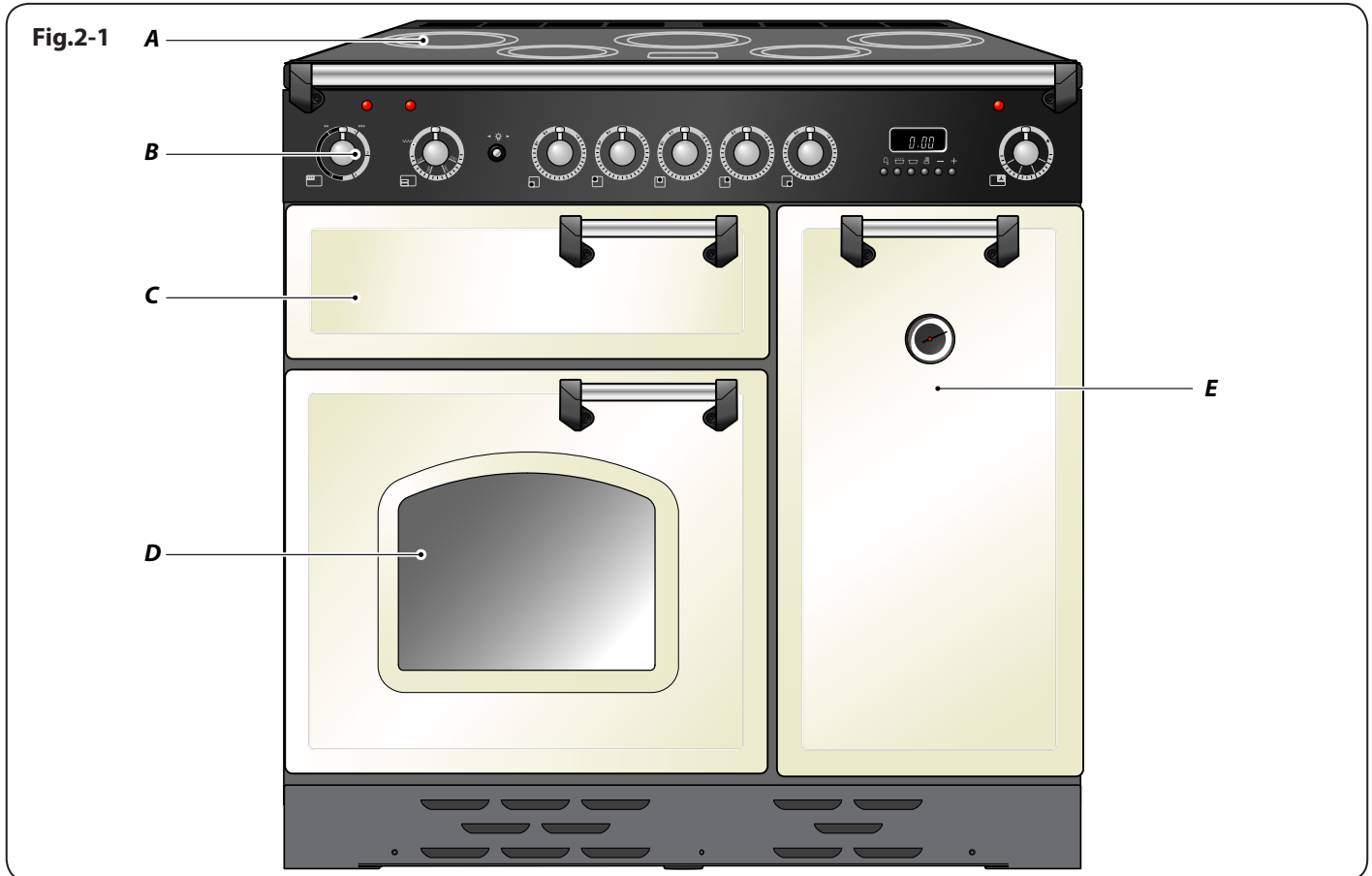

Fig.1-4

2. Cooker Overview



The 90 induction cooker (**Fig.2-1**) has the following features:

- A.** 5 induction cooking zones
- B.** A control panel
- C.** A separate grill
- D.** Main programmable fan oven
- E.** Tall fan oven

The Hob

Use only pans that are suitable for induction hobs. We recommend stainless steel, enamelled steel pans or cast iron pans with enamelled bases. Note that some stainless steel pans are not suitable for use with an induction hob so please check carefully before purchasing any cookware.

Pans made of copper, aluminium or ceramic are not suitable for use on an induction hob. *The kind of pan you use and the quantity of food affects the setting required. Higher settings are required for larger quantities of food.*

Pots and pans should have thick, smooth, flat bottoms (**Fig.2-2**). This ensures the maximum heat transfer from the hob to the pan, making cooking quick and energy efficient. Never use a round-bottomed wok, even with a stand.

The very best pans have bases that are very slightly curved up when cold (**Fig.2-3**). If you hold a ruler across the bottom you will see a small gap in the middle. When they heat up the metal expands and lies flat on the cooking surface.

Make sure that the base of the pan is clean and dry to prevent any residue burning onto the hob panel. This also helps prevent scratches and deposits.

Always use pans that are the same size as (or slightly larger than) the areas marked on the hob. Using a lid will help the contents boil more quickly.

⚠ Always take care before touching the surface, even when the hob is turned off. It may be hotter than you think!

The induction hob comprises of five cooking zones containing induction elements with different ratings and diameters (**Fig.2-4**) each with a pan detector and residual heat indicator, and a hob control display.

The hob control display (**Fig.2-5**) informs you of the following induction hob functions:

- ☐ Pan detector
- H Residual heat indicator
- A Automatic heat-up
- L Child lock

Pan Detector, ☐

IMPORTANT: After use, switch off the hob element by its control and **DO NOT RELY** on the pan detector.

If a cooking area is switched on and there is no pan in place or if the pan is too small for the cooking area, then no heat will be generated. The symbol [☐] will appear on the hob control display; this is the “pan-missing symbol”. Place a pan of the correct size on the cooking area and the [☐] symbol will disappear and cooking can begin. After 10 minutes without detecting a pan the cooking zone will switch off automatically.

Table 2-1 shows the minimum pan sizes recommended for each cooking zone.

Note: Using pans with a base diameter smaller than those recommended will result in a power reduction.

Residual Heat Indicator, H

After use, a cooking zone will remain hot for a while as heat dissipates. When a cooking zone is switched off the residual heat indicator symbol [H], will appear in the display. This shows that the cooking zone temperature is above 60 °C and may still cause burns. Once the temperature has dropped to below 60 °C the [H] will go out.

Automatic Heat-up, A

This function is available on all of the cooking areas. It allows rapid heating up of the element to bring the selected cooking zone up to temperature. Once the zone is at the required cooking temperature the power level will reduce automatically to the preset level.

The function is selected by turning the control knob to the ‘A’ position. This can be selected by either turning the control knob momentarily anti-clockwise from the zero position or clockwise past the ‘9’ until the symbol [A] is shown on the hob control display. Once the [A] is displayed, turn the control knob to the level of your choice (1 to 9). The pan will

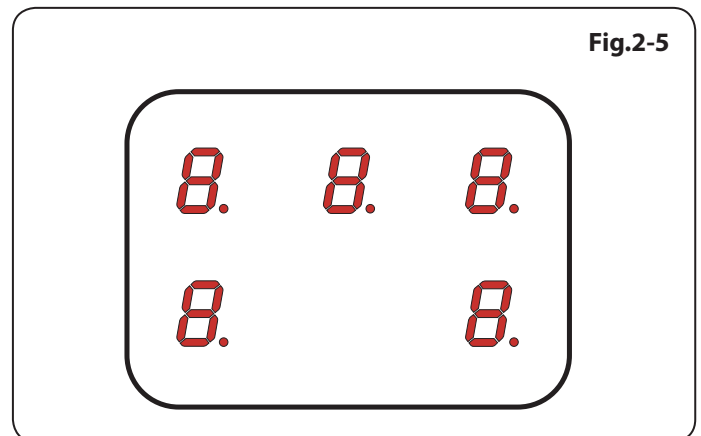
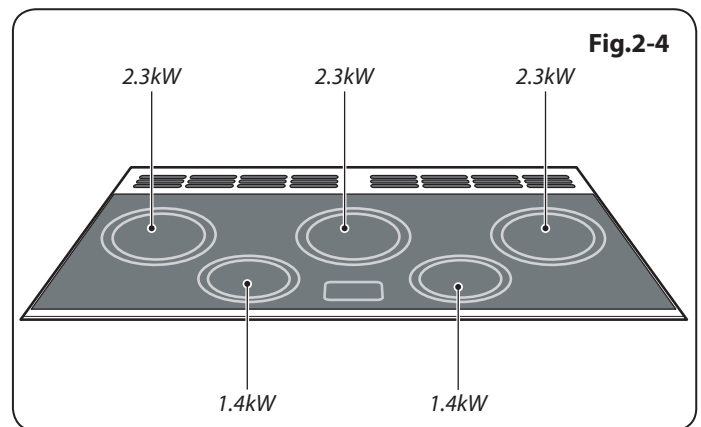

Cooking Zone	Minimum Pan Diameter (Pan base) mm
Front left	140
Rear left	180
Centre	180
Rear right	180
Front right	140

Table 2-1

Power Level	Automatic heat-up time at 100% (min:sec)
1	0:48
2	2:24
3	3:48
4	5:12
5	6:48
6	2:00
7	2:48
8	3:36
9	0:10

Table 2-2

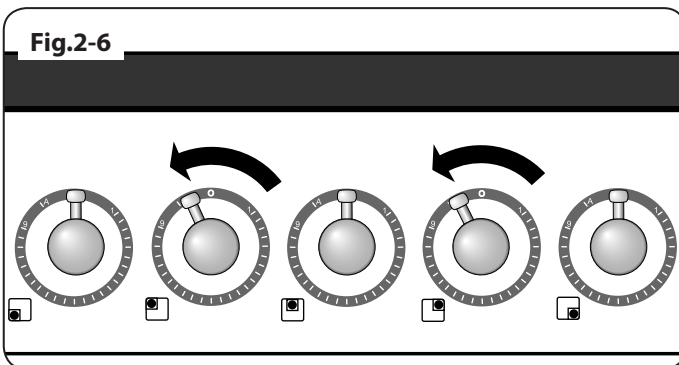

heat up at 100% power for a specified time before the power is reduced to the level selected.

When the Automatic Heat-up function is activated, the hob control display will flash alternately between the [P] setting and the chosen power level.

Once the automatic heat-up time has ended the hob control display will stop flashing and will display the chosen power level.

The Automatic Heat-up function can be stopped by either turning the control knob back to the "0" power setting or turning the control knob to the "9" power setting.

For your guidance **Table 2-2** shows the time available at 100% power depending on the power level selected in the Automatic Heat-up mode.

Child Lock, L

To prevent the unwanted use by children, the hob can be locked.

IMPORTANT: This can only be activated when all the cooking zones are switched off.

To lock the hob, first turn on any of the hob controls on then off – this will activate the hob display – then simultaneously turn both rear outer induction controls anti-clockwise (**Fig.2-6**) until [L] appears in the hob control display for all cooking areas.

This will NOT affect the ovens or grill; they can still be used.

To unlock the hob, simultaneously turn both rear outer induction controls anti-clockwise until the [L] symbol disappears.

Boil Dry Function

This is an integrated pan protection feature, designed to minimise overheating of the cookware. This function identifies when the temperature of the pan rises rapidly and works to maintain a safe level of pan temperature. It should not interfere with normal cooking.

⚠ Please remember not to leave the hob unattended. Care should be taken to not allow your cookware to boil dry.

The Grill / Glide-out Grill

Open the door and pull the grill pan (Fig.2-7) or carriage (Fig.2-8) forward using the handle.

The grill has two elements that allow either the whole area of the pan to be heated or just the right-hand half.

Adjust the heat to suit by turning the knob. To heat the whole grill, turn the knob clockwise (Fig.2-9).

To heat the right-hand half, turn the knob anti-clockwise. The neon indicator light by the grill control will come on.

For best results, leave the grill pan in the grill chamber and preheat the appropriate part(s) of the grill for two minutes. The grill trivet can be removed and the food placed on it while you are waiting for the grill to preheat.

⚠ DO NOT leave the grill on for more than a few moments, without the grill pan underneath it, otherwise the knobs may become hot.

Once the grill has preheated, take the grill pan out again and put the trivet back in place with the food on it. Slide the grill pan or carriage back into the grill chamber. Make sure that it is pushed right in.

⚠ Accessible parts may be hot when the grill is in use. Young children should be kept away.

The grill pan trivet can be turned over to give two grilling positions (Fig.2-10).

⚠ Never close the grill door when the grill is on.

⚠ DO NOT leave the grill on for more than a few moments, without the grill pan underneath it, otherwise the knobs may become hot.

The Ovens

The clock must be set to the time of day before the left-hand oven will work. See the following section on 'The Clock' for instructions on setting the time of day.

References to 'left-hand' and 'right-hand' ovens apply as viewed from the front of the appliance.

Both ovens are fanned ovens.

Fanned ovens circulate hot air continuously, which means faster, more even cooking. The recommended cooking temperatures for a fan oven are generally lower than those for a non-fan oven.

Operating the Ovens

Turn the oven knob to the desired temperature (Fig.2-11).

The oven indicator light will glow until the oven has reached the temperature selected. It will then cycle on and off during cooking.

When cooking foods with high water content, there may be some steam visible at the grille at the rear of the hotplate. This is perfectly normal.

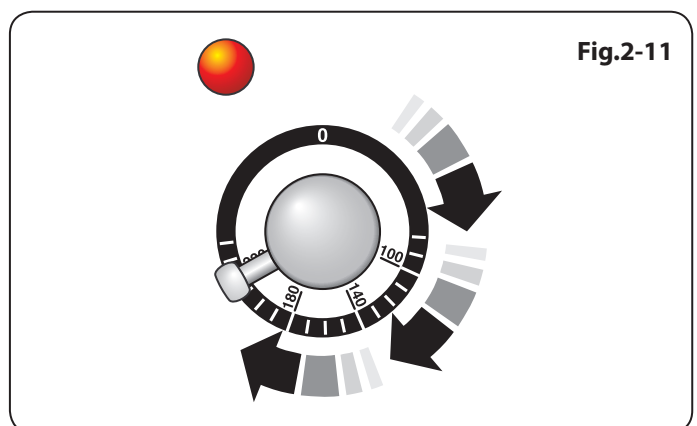
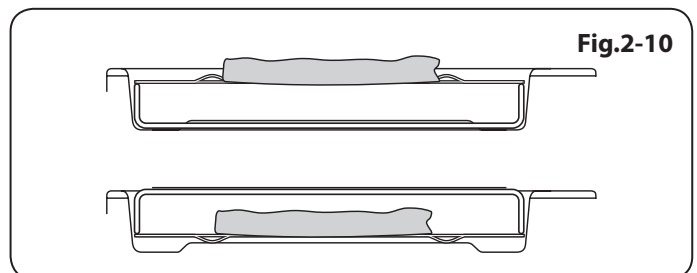
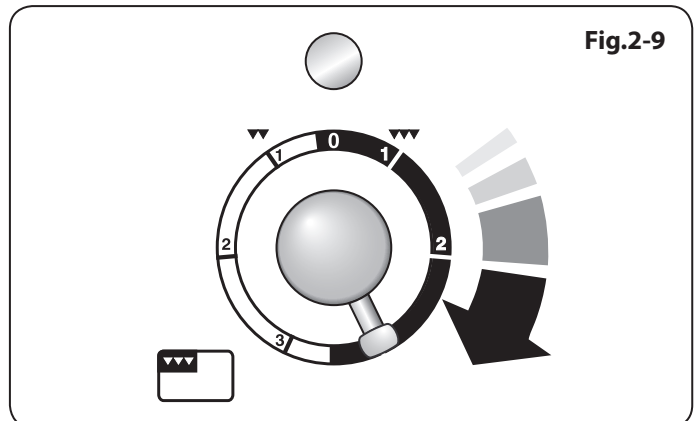
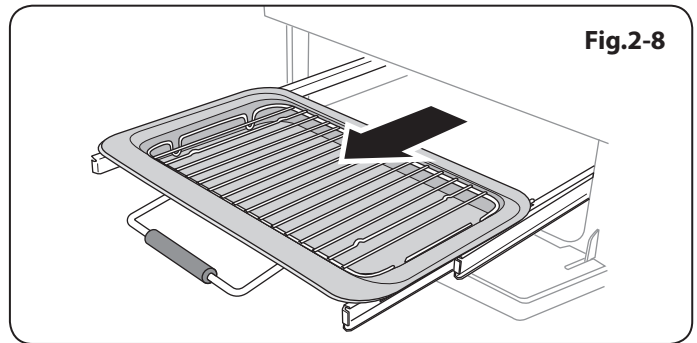
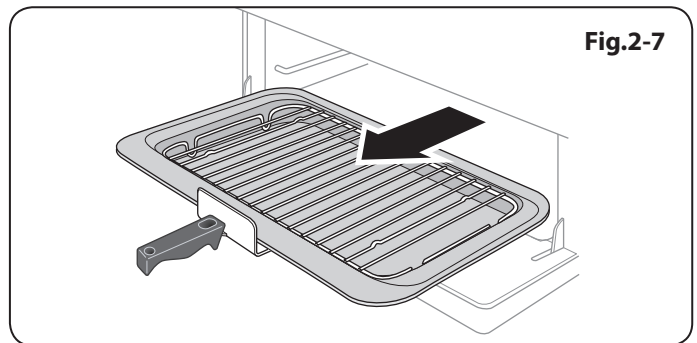

Fig.2-12

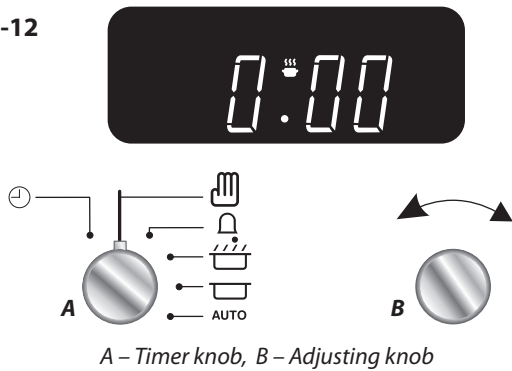

Fig.2-13

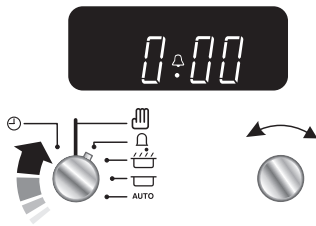

Fig.2-14

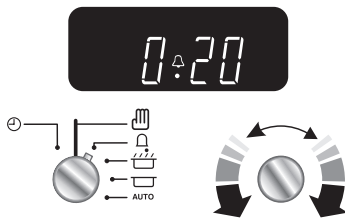

Fig.2-15

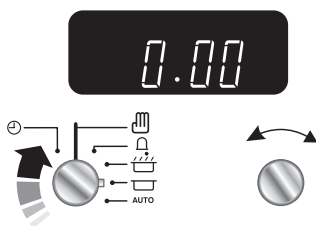

Fig.2-16

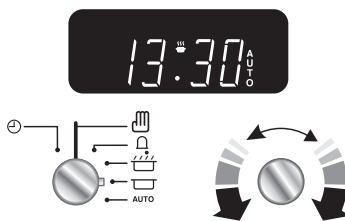

Fig.2-17

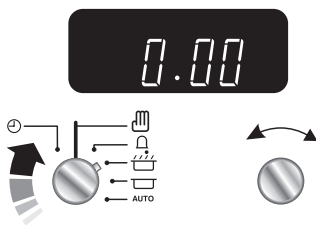
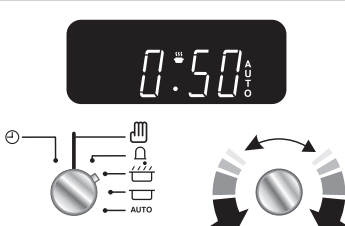

Fig.2-18



The Clock

You can use the clock to turn the left-hand oven on and off. **The clock must be set to the time of day before the oven will work.**

Note: When using the timer functions, first set the clock as required before setting the oven temperature and selecting the oven function (multi-function ovens only).

The 2-button Clock (*Professional+ only*)

Setting the time of day

The 2-button LCD clock is shown in (Fig.2-12). When the clock is first connected, the display flashes (0.00) and (⏰) alternately.

To set the time, turn and hold the Timer knob to the clock symbol (⏰) and at the same time turn the Adjusting knob left or right until the clock shows the time of day. Remember this is a 24-hour clock. Let go of the Timer knob and it will spring back to the vertical, oven manual setting.

IMPORTANT: The left-hand oven will not operate unless the clock has been set.

Setting the minute minder

To activate the minute minder turn the Timer knob to the right to the (⏰) minute minder setting – it should click into position (Fig.2-13).

Rotate the Adjusting knob to set the time required (Fig.2-14).

You can either turn the knob back to the vertical manual setting (⏱) to keep an eye on the time of day, or leave it in the (⏰) minute minder position as the time ticks down.

To stop the beeper when it sounds, turn the Adjusting knob anti-clockwise.

- The 'cook period', which is the length of time you want the oven to cook for.
- The 'stop time', which is the time of day you want the oven to stop cooking.

To stop the oven at a specific time of day

Turn the Timer knob to the (⏱) position (Fig.2-15).

Use the Adjusting knob to set the 'stop time'. You can set the oven to turn on at any time over the following 24-hour period. AUTO shows in the display (Fig.2-16).

Turn the Timer knob to the bottom 'AUTO' setting to return to the clock display.

Once the 'stop time' is reached, the beeper sounds. Turn the Timer knob to the vertical (⏱) to return to manual cooking.

To start and then stop the oven using the Timer

You cannot set a start time directly – this is set automatically by a combination of the 'cook time' and 'stop time'.

Turn the Timer knob to the (⏱) position (Fig.2-17).

Turn the Adjusting knob to set the 'cooking time' you need (Fig.2-18).

Turn the Timer knob to the (☐) position. The display will show the current time of day plus the 'cook time' you just set. Use the Adjusting knob to set the 'stop time' required (Fig.2-19).

The 'stop time' is displayed, followed by 'AUTO'. Set the oven to the cooking temperature you need. Turn the Timer knob to the 'Auto' setting.

When your cooking is finished, the beeper sounds. Turn the Timer knob to the vertical (⏏) to return to manual cooking.

If you are out, do not worry about the beeper going off – it stops on its own after a while. When you return, turn the Timer knob to the vertical (⏏) to return to manual cooking.

AUTO is showing, but you want to revert to manual cooking

You can cancel any automatic settings by briefly turning the Timer knob to the clock symbol (⌚) and then releasing it.

Key Lock

When the key lock is activated the left-hand oven is locked and will not come on.

The right-hand oven can be operated as usual.

To activate the key lock

Make sure that the clock is in manual mode and cancel any active programs.

Turn and hold the Timer knob to the clock symbol (⌚) for about 8 seconds. 'On' appears on the display (Fig.2-20).

While still holding the Timer knob turned to the clock symbol (⌚), turn the Adjusting knob clockwise until the key symbol (🔑) and 'OF' shows on the display (Fig.2-21). Release the knobs.

The left-hand oven is now locked, as is confirmed by the display showing the time of day alongside the key symbol (🔑).

When the key lock is activated, the left-hand oven is locked and will not come on (Fig.2-22).

To turn off the key lock

Turn and hold the Timer knob to the clock symbol (⌚) for about 8 seconds. 'OF' will appear on the display (Fig.2-23).

While still holding the Timer knob turned to the clock symbol (⌚), turn the Adjusting knob clockwise until the key symbol (🔑) goes out on the display and 'On' shows (Fig.2-24). Let go of the knobs.

After a few seconds, the display reverts to showing the time of day.

The oven can now be used normally.

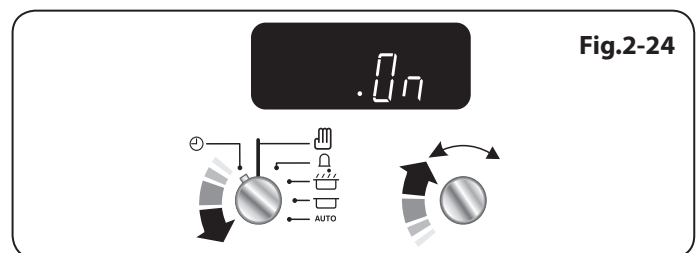
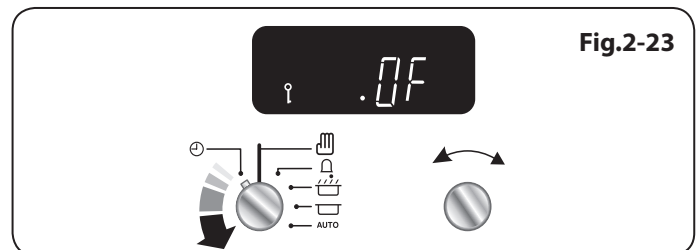
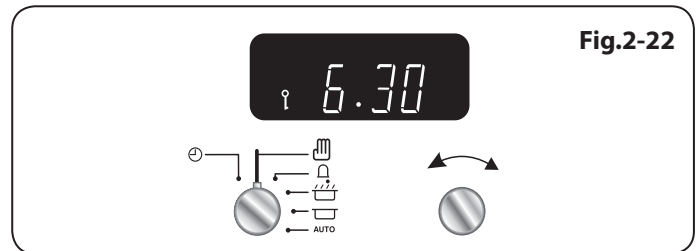
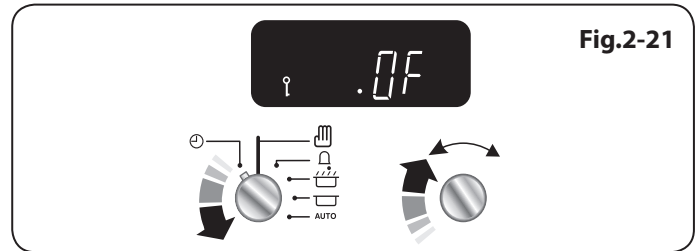
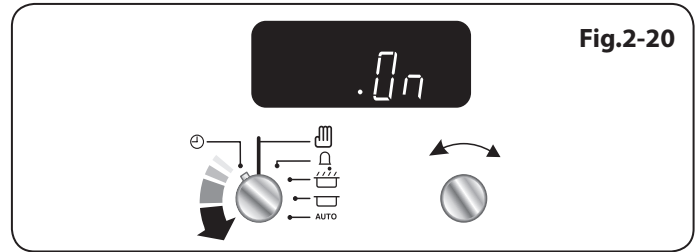
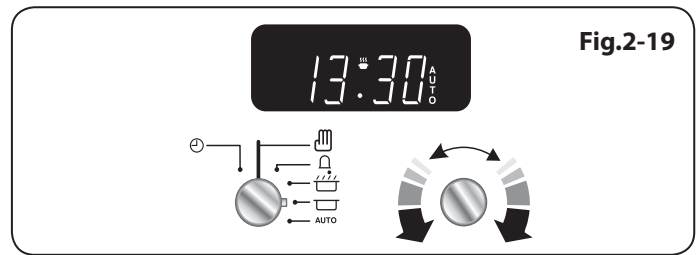

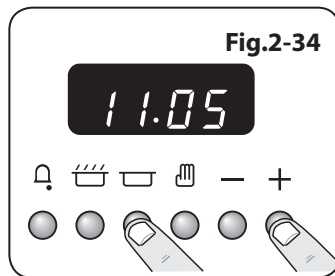
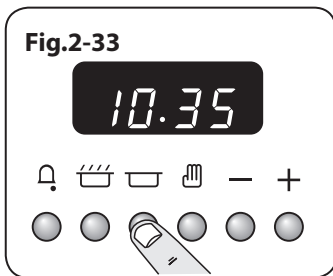
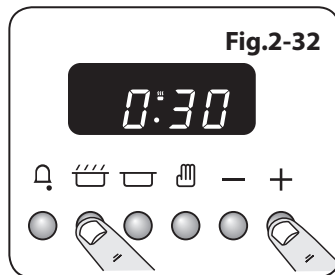
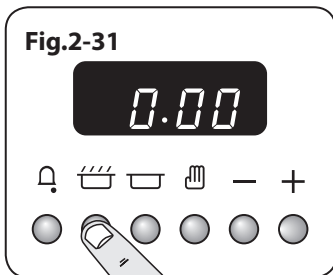
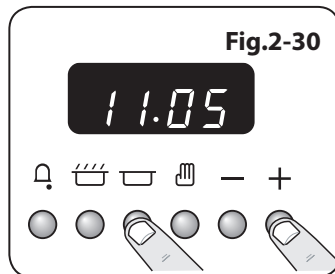
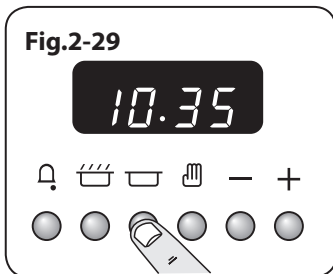
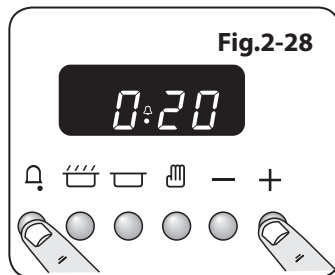
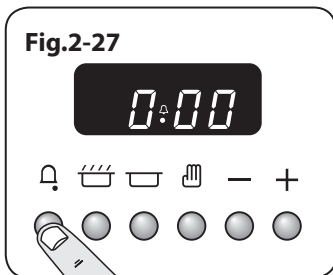
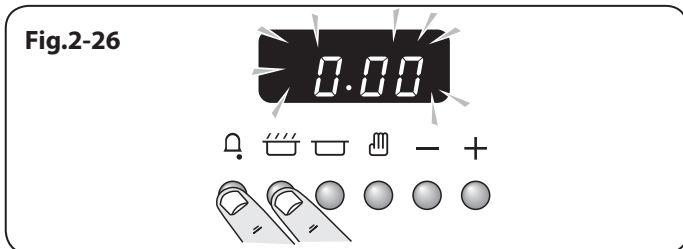
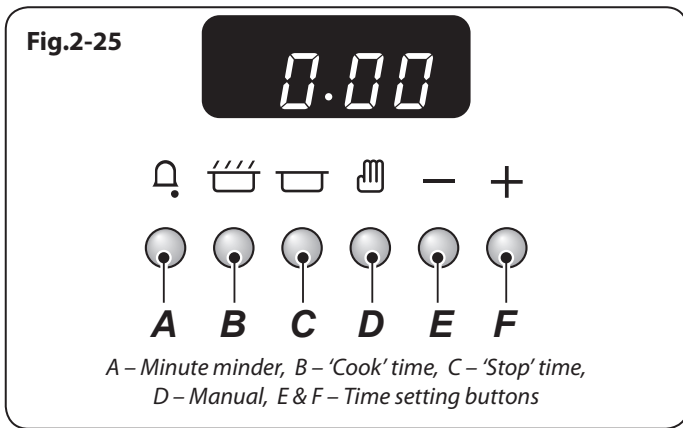

The 6-button Clock (Classic & Toledo models)

Setting the time of day

The 6-button LCD clock is shown in **Fig.2-25**. When the clock is first connected the display flashes (0.00) and () alternately.

Press and hold both the [A] and [B] buttons down (**Fig.2-26**). Now press the [+] button (or the [-] button) until the correct time shows.

Do not forget that it is a 24-hour clock.

If you need to reset the cooker, turn off the power supply and wait for a couple of minutes and start again.

Setting the minute minder

Press and hold the [A] button (**Fig.2-27**), and then press the [+] button until the length of time you want to cook for is shown (**Fig.2-28**).

You can check the time remaining by pressing [A]. When the beeper sounds cancel it by pressing [A].

- The 'cook period', which is the length of time you want the oven to cook for.
- The 'stop time', which is the time of day you want the oven to stop cooking.

To stop the oven automatically

Press and hold the Stop Time [C] button (**Fig.2-29**) and then press the [+] button (or [-] button) until the required 'stop time' shows (**Fig.2-30**). AUTO will show in the display.

Once the 'stop time' is reached, the beeper sounds. To stop the beep turn the oven control knob to 0 first and then press [D] once; press [D] again to return to manual cooking.

To start and stop the oven automatically

Before you set the clock you must have two numbers clearly in mind – the 'cook period' and the 'stop time'.

Note: You cannot set a start time directly – this is set automatically by setting the 'cook period' and the 'stop time'.

Press and hold the [B] button (**Fig.2-31**) and then press the [+] button (or [-] button) until the required 'cook period' shows (**Fig.2-32**).

Now press and hold the [C] button (**Fig.2-33**) and then press the [+] button (or [-] button) until the required 'stop time' shows (**Fig.2-34**). Release the buttons.

AUTO will now show in the display.

Set the oven to the required temperature. When cooking is finished the beeper will sound. Turn the oven knob to the OFF position first, and then press the [D] button once to stop the beep; press it again to return to manual cooking.

If you are out, do not worry about the beeper going off, it stops after a while. When you return, turn the oven knob to 0 first, and then press [D] twice to return to manual cooking.

AUTO is showing, you want to reset to manual cooking

To return to manual cooking from any automatic setting, the 'cook period' must be cancelled. Press and hold the [⏏] button and then press the [-] button until the display reads (0.00).

Press the [👤] button to return to manual cooking.

Key Lock

Activating the key lock will lock the left-hand oven and it will not come on.

The right-hand oven can be operated as usual.

To activate the key lock

Make sure that the clock is in manual mode and cancel any active programs.

Hold the Minute Minder [🕒] and Cook period [👤] buttons. When 'On' appears on the display (**Fig.2-35**) press the [+] button once. The key symbol [🔒] and 'OF' will now show on the display (**Fig.2-36**). Release the buttons.

The left-hand oven is now locked, as confirmed by the display showing the time of day alongside the key symbol (**Fig.2-37**).

To turn off the key lock

Hold the Minute Minder [🕒] and Cook period [👤] buttons. When 'OF' appears on the display (**Fig.2-38**) press the [+] button once. The key symbol [🔒] will go out and 'On' will show on the display (**Fig.2-39**). Release the buttons.

After a few seconds the display will revert to show the time of day.

The oven can now be used normally.

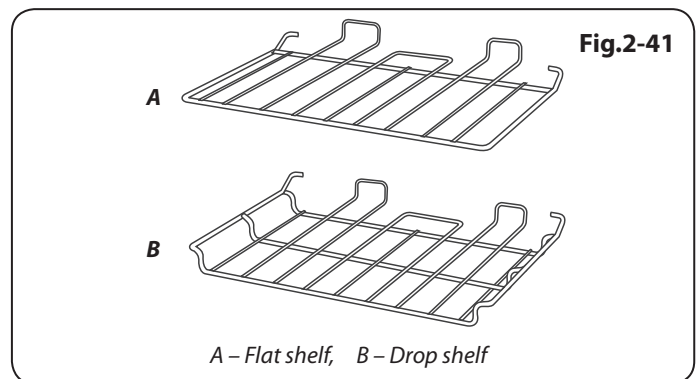
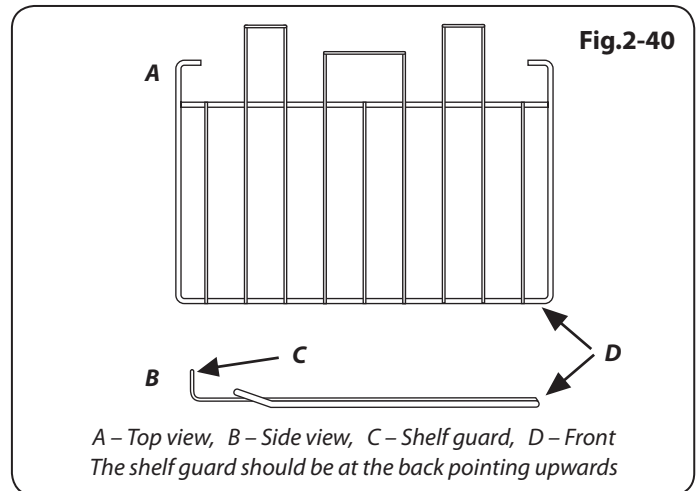
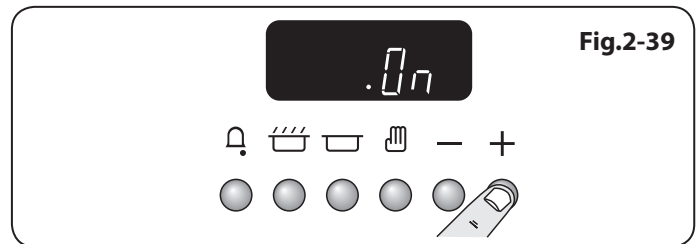
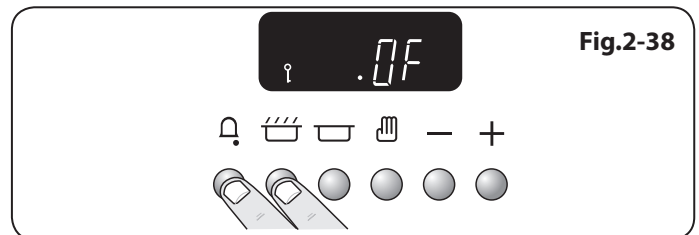
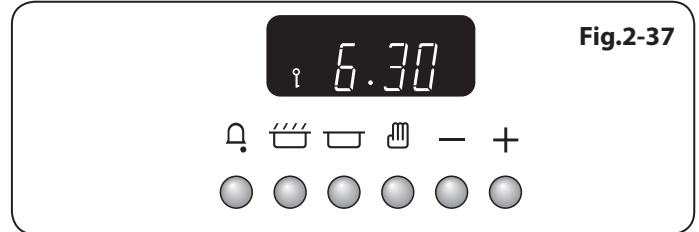
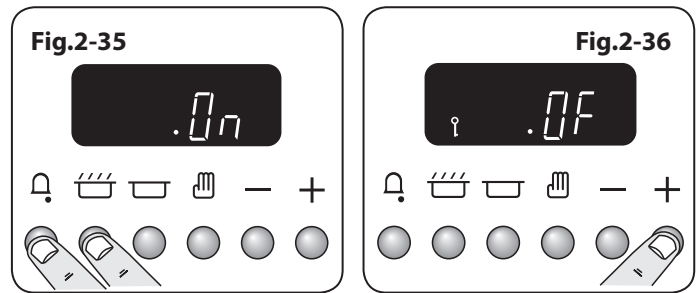

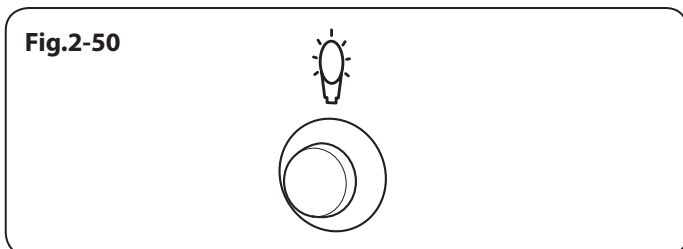
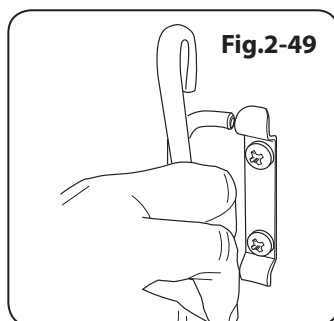
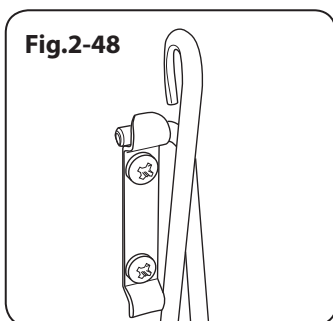
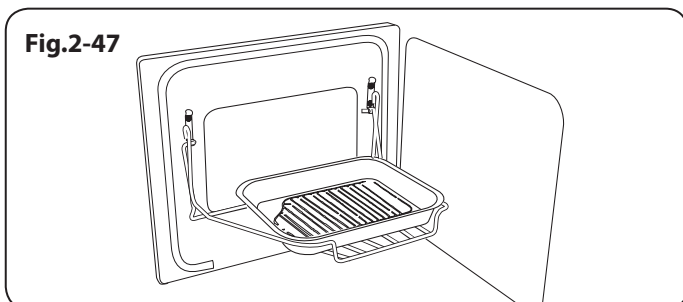
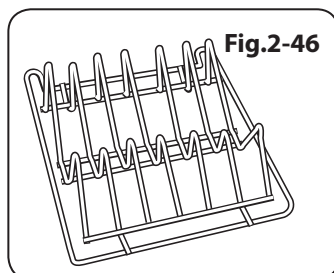
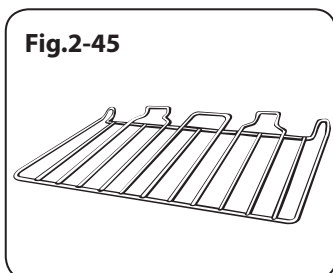
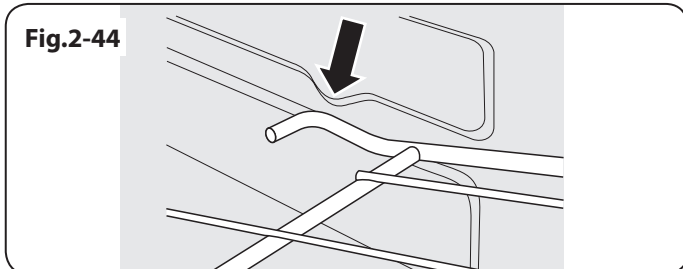
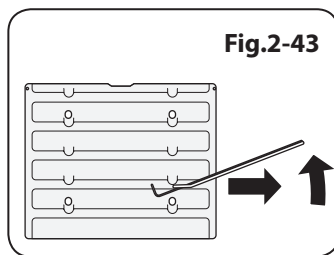
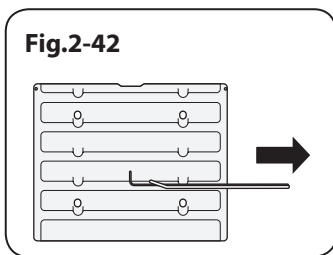

Accessories

Oven Shelves – Left-hand (Main) Oven

In addition to the flat shelves (Fig.2-40), some models are supplied with a drop shelf (Fig.2-41). The drop shelf increases the possibilities for oven shelf spacing.

The oven shelves can be easily removed and refitted.

Pull the shelf forward until the back of the shelf is stopped by the shelf stop bumps in the oven sides (Fig.2-42).

Lift up the front of the shelf so the back of the shelf will pass under the shelf stop and then pull the shelf forward (Fig.2-43).

To refit the shelf, line up the shelf with a groove in the oven side and push the shelf back until the ends hit the shelf stop. Lift up the front so the shelf ends clear the shelf stops, and then lower the front so that the shelf is level and push it fully back (Fig.2-44).

Oven shelves – Right-hand (Tall) Oven

The tall oven is supplied with four flat cooking shelves (Fig.2-45) and a plate warming shelf (Fig.2-46).

When using the tall oven, you can cook on all four shelves at the same time, but make sure that they are well spaced out allow the hot air to circulate.

The Handyrack (Main Oven)

The Handyrack (Fig.2-47) fits to the left-hand oven door only. Food cooking on it is easy to attend to, because it is accessible when the door is open.

The maximum weight that can be held by the Handyrack is 5.5 kg (12 lb). It should only be used with the supplied roasting tin, which is designed to fit the Handyrack. Any other vessel could be unstable.

It can be fitted at two different heights. One of the oven shelves must be removed and the other positioned to suit.

When the Handyrack is used in its highest position, other dishes can be cooked on the bottom shelf position or base of the oven.

When the Handyrack is used in its lowest position, other dishes can be cooked on the second shelf position or base of the oven.

To fit the Handyrack, locate one side of it on the door bracket (Fig.2-48).

Then spring the other side out to clip it onto the other bracket (Fig.2-49).

Main Oven Light

Press the button to turn the light on (Fig.2-50).

If the oven light fails, turn off the power supply before changing the bulb. See the 'Troubleshooting' section for details on how to change the bulb.

3. Cooking Tips

Using your Induction Cooker

If you have not used an induction cooker before please be aware of the following:

- Ensure that the pans you have or buy are suitable for use on the Induction hob. Stainless steel, enamelled steel or cast iron is ideal. Double check before you buy pans – they must have magnetic bases.
- Allow time to get used to induction cooking; it is fast and powerful as well as being gentle. When simmering, you may notice that liquids appear to stop bubbling and then start again almost immediately. This is perfectly normal.
- You may notice a faint vibrating sound coming from the pans when using the induction hob. Again, this is perfectly normal and will depend upon the type and style of pans you are using.
- The induction heating elements will phase on and off when cooking. Although an active cooking zone may appear to switch on and off, a constant heat is still being supplied to the base of the pan – this is completely normal.

Tips on Cooking with the Timer

If you want to cook more than one dish, choose dishes that require approximately the same cooking time. However, dishes can be 'slowed down' slightly by using small containers and covering them with aluminium foil, or 'speeded up' slightly by cooking smaller quantities or placing them in larger containers.

Very perishable foods such as pork or fish should be avoided if a long delay period is planned, especially in hot weather.

 **DO NOT place warm food in the oven to be timed.**

 **DO NOT use a timed oven that is already warm.**

 **DO NOT use the timed oven if the adjoining oven is already warm.**

Whole poultry must be thoroughly defrosted before being placed in the oven. Check that meat and poultry are fully cooked before serving.

General Oven Tips

The wire shelves should always be pushed firmly to the back of the oven.

Baking trays with food cooking on them should be placed level with the front edge of the oven's wire shelves. Other containers should be placed centrally. Keep all trays and containers away from the back of the oven, as overbrowning of the food may occur.

For even browning, the maximum recommended size of a baking tray is 340 mm (13½") by 340 mm (13½") in the main oven and 232 mm (9⅛") and 321 mm (12⅝") in the tall oven.

When the oven is on, do not leave the door open for longer than necessary, otherwise the knobs may get very hot.

- Always leave a 'fingers width' between dishes on the same shelf. This allows the heat to circulate freely around them.
- To reduce fat splashing when you add vegetables to hot fat around a roast, dry them thoroughly or brush lightly with cooking oil.
- Where dishes may boil and spill over during cooking, place them on a baking tray.
- The Cook & Clean oven liners (see 'Cleaning Your Cooker') work better when fat splashes are avoided. Cover meat when cooking.
- Sufficient heat rises out of the oven while cooking to warm plates in the grill compartment.
- If you want to brown the base of a pastry dish, preheat the baking tray for 15 minutes before placing the dish in the centre of the tray.

4. Cooking Table

The oven control settings and cooking times given in the table below are intended to be used **AS A GUIDE ONLY**. Individual tastes may require the temperature to be altered to provide a preferred result.

Food is cooked at lower temperature in a fan oven than in a conventional oven. When using recipes, reduce the fan oven temperature by 10°C and the cooking time by 5-10 minutes. The temperature in the fanned oven does not vary with height in the oven so you can use any shelf.

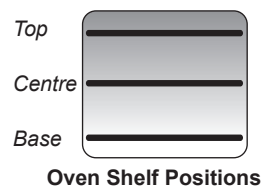

Food	Conventional Oven		Fan Oven		Approximate cooking time	
	Temperature °C	Shelf position	Temperature °C			
Meat						
Beef (no bone)	160	C	150	30-35 minutes per 500g +30-35 minutes.	<i>Thoroughly thaw frozen joints before cooking. Meat may be roasted at 220°C (210°C for fan oven) and the cooking time adjusted accordingly. For stuffed and rolled meats, add approximately 10 minutes per 500g, or cook at 200°C (190°C) for 20 minutes then 160°C (150°C) for the remainder.</i>	
	200	C	190	20-25 minutes per 500g +20-25 minutes.		
Lamb	160	C	150	30-35 minutes per 500g +30-35 minutes.		
	200	C	190	25-30 minutes per 500g +25-30 minutes.		
Pork	160	C	150	35-40 minutes per 500g +35-40 minutes.		
	200	C	190	25-30 minutes per 500g +25-30 minutes.		
Poultry						
Chicken	160	C	150	20-25 minutes per 500g +20-25 minutes.	<i>For stuffed poultry, you could cook at 200°C (190°C) for 20 minutes then 160°C (150°C) for remainder. Do not forget to include the weight of the stuffing. For fresh or frozen prepacked poultry, follow instructions on the pack. Thoroughly thaw frozen poultry before cooking.</i>	
	200	C	190	15-20 minutes per 500g +15-20 minutes.		
Turkey	160	C	150	20 minutes per 500g +20 minutes.		
	200	C	190	15 minutes per 500g +15 minutes.		
Duck	160	C	150	25-30 minutes per 500g.		
	200	C	190	20 minutes per 500g.		
Casserole	140-150	C	130-140	2-4 hours according to recipe.		
Yorkshire pudding	220	T	210	Large tins 30-35 minutes; individual 10-20 minutes.		
Fish						
Fillet	190	C/B	180	15-20 minutes.		
Whole	190	C/B	180	15-20 minutes per 500g.		
Steak	190	C/B	180	Steaks according to thickness.		
Cake						
Very rich fruit - Christmas, wedding, etc.	140	C/B	130	45-50 minutes per 500g of mixture.	<i>Using the conventional oven: when two tier cooking leave at least one runner space between shelves. Position the baking tray with the front edge along the front of the oven shelf.</i>	
Fruit 180 mm tin	150	C/B	140	2-2½ hours.		
Fruit 230 mm tin	150	C/B	140	Up to 3½ hours.		
Madeira 180 mm	160	C	150	80-90 minutes.	<i>Up to three tiers can be cooked in a fan oven at the same time but make sure to leave at least one runner space between each shelf being cooked on.</i>	
Queen cakes	190	C	180	15-25 minutes.		
Scones	220	C	210	10-15 minutes.		
Victoria sandwich						
180 mm tin	180	C	170	20-30 minutes.		
210 mm tin	180	C	170	30-40 minutes.		
Desserts						
Shortcrust tarts	200	C	190	20-30 minutes on a preheated tray.	<i>Using the conventional oven: for even browning the maximum size of baking tray recommended is 340 mm x 340 mm. This ensures free heat circulation. If cooking a two tier load, the trays should be interchanged approximately halfway through the cooking time.</i>	
Fruit pies	200	C	190	35-45 minutes.		
Tartlets	200	C	190	10-20 minutes according to size.		
Puff pastry	230	C	220	20-40 minutes according to size.		
Meringues	100	C	90	2-3 hours.		
Baked egg custard	160	C	150	45-60 minutes.		
Baked sponge pudding	190	C	180	40-45 minutes.		
Milk pudding	140-150	C/B	130-140	2 to 3 hours.		
Bread	220	C/T	210	20-30 minutes.		

5. Cleaning Your Cooker

Isolate the electricity supply before carrying out any major cleaning. Allow the cooker to cool.

Never use paint solvents, washing soda, caustic cleaners, biological powders, bleach, chlorine based bleach cleaners, coarse abrasives or salt. Do not mix different cleaning products – they may react together with hazardous results.

All parts of the cooker can be cleaned with hot soapy water – **but take care that no surplus water seeps into the appliance.**

Remember to switch the electricity supply back on and reset the clock before reusing the cooker.

Hob

Daily Care

First of all make sure that all heat indicator lights are off and that the cooking surface is cool. Apply a small dab of ceramic cleaning cream in the centre of each area to be cleaned. Dampen a clean paper towel and work the cream onto the cooking surface. As a final step, wipe the cooking surface with a clean, dry paper towel.

Cleaning Spills

For spills and boil-overs that occur while cooking, turn the unit off and wipe the area surrounding the hot zone with a clean paper towel. If a spill (other than a sugary substance) is on the hot zone, do not clean until the unit has completely cooled down, and then follow the instructions below (*'Cleaning burned-on spills'*).

If you accidentally melt anything on the surface, or if you spill foods with a high sugar content (preserves, tomato sauce, fruit juice, etc.), remove the spill **IMMEDIATELY** with a razor scraper, while the unit is still hot.

IMPORTANT: Use an oven glove to protect your hand from potential burns.

Scrape the major spill or melted material from the cooking zone and push into a cold area. Then, turn the unit 'OFF' and allow it to cool before cleaning further. After the cooking surface cools down and the heat indicator lights go off, follow the *'Daily Care'* procedure outlined above.

Cleaning Burned-on Spills

Make sure that the heat indicator lights are off and that the hob is cool. Remove the excess burned-on substance with a single-edged razor scraper. Hold the scraper at an angle of about 30° to the surface and then scrape off the burned-on matter (**Fig.5-1**).

Once you have removed as much as possible with the scraper, follow the *'Daily Care'* procedure outlined above.

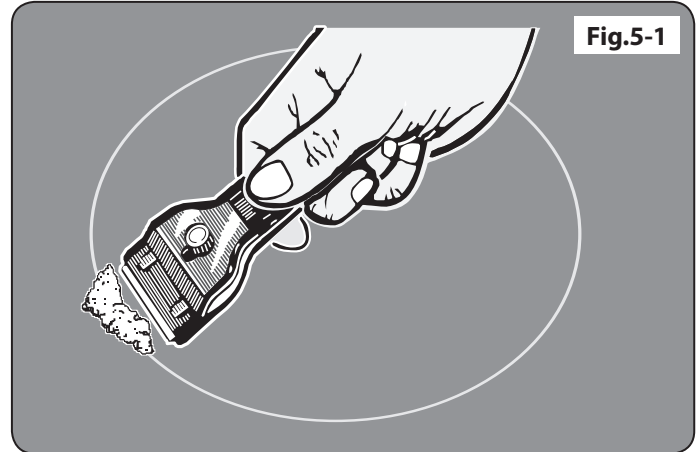
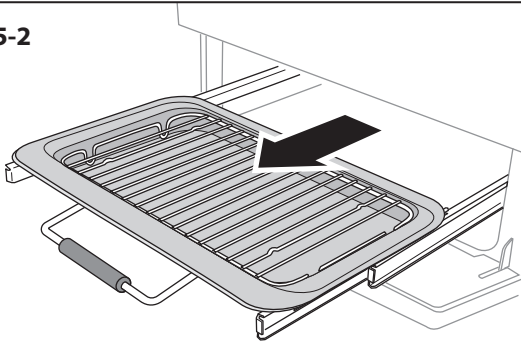

Fig.5-2



Grills

The grill pan and grid should be washed in hot soapy water. After grilling meats or any foods that soil, leave to soak for a few minutes immediately after use. Stubborn particles may be removed from the grid using a nylon brush. Alternatively, the grill pan can be washed in a dishwasher.

⚠ Before you remove any of the grill parts for cleaning, ensure that they are cool, or use oven gloves.

⚠ DO NOT use any abrasive substances.

Cleaning the Glide-out Grill

The grill pan can be easily removed for cleaning as follows. Remove the grill pan support frame by pulling the grill pan forward (Fig.5-2).

Lift the grill pan clear of the support frame. The support frame is held to the side rails by two clips on each side (Fig.5-3).

For each side, support the side rail with one hand and with the other hand lift the frame up and out of the side clips (Fig.5-4).

For safety, push the side rails back into the grill chamber.

If you need to remove the side rails to allow cleaning of the grill chamber, you can unhook them from the grill chamber sides (Fig.5-5) and wipe the sides clean with a soft cloth and mild detergent.

⚠ DO NOT put the side runners in a dishwasher.

Once you have finished, hook the side rails back onto the sides of the chamber. To refit the frame, pull the side rails forward and, for each side in turn, support the side rail and press the frame down into the side rails. Replace the grill pan. When refitting the grill pan, ensure that the wide rim is at the front (Fig.5-6).

Control Panel and Doors

Avoid using any abrasive cleaners, including cream cleaners, on brushed stainless steel surfaces. For best results, use a liquid detergent or multi-purpose cleaner.

The same cleaner can also be used on the doors. Alternatively, use a soft cloth wrung out in clean hot soapy water. You can use the same method for cleaning the control panel and knobs. After cleaning, polish with a dry cloth.

Ovens

The oven door front panels can be taken off so that the glass panels can be cleaned. Move the cooker forward to gain access to the sides (see the 'Moving the Cooker' section under 'Installation').

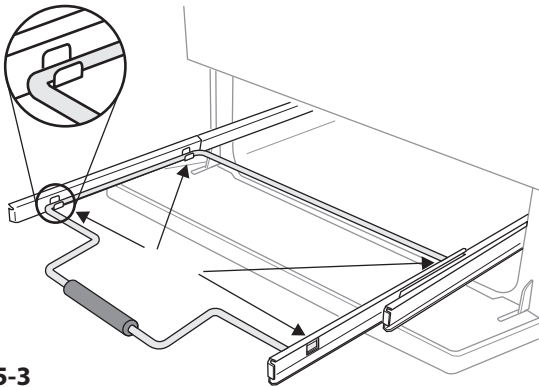

Fig.5-3

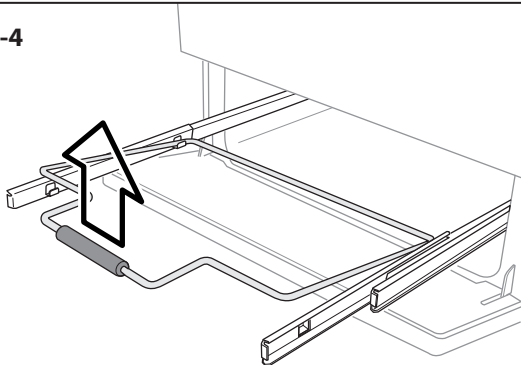

Fig.5-4

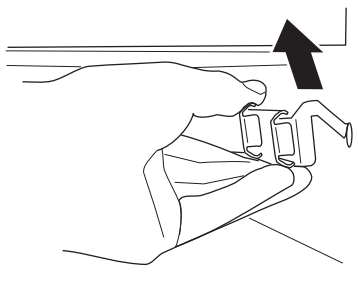

Fig.5-5

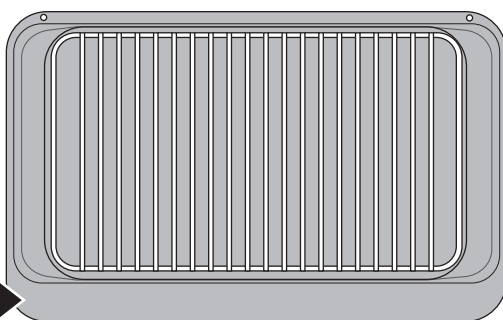

Fig.5-6

Glass Door Panels *(some models)*

The oven door front panels can be taken off so that the glass panels can be cleaned. Move the cooker forward to gain access to the sides (see the 'Moving the Cooker' section under 'Installation').

Open the oven door slightly and remove the front panel fixing screws from the door sides, two each side (**Fig.5-7**).

Carefully lift off the outer door panel. The inside face of the glass panels can now be cleaned – take care not to disturb or wet the door insulation.

Note: If the door is triple glazed then the inner two panels are fixed together and should not be separated. After cleaning, carefully refit the outer door panel and replace the side fixing screws.

⚠ DO NOT use harsh abrasive cleaners or sharp metal scrapers to clean the oven door glass since they can scratch the surface, which may result in shattering of the glass.

'Cook & Clean' Panels

The main oven has side 'Cook & Clean' panels which have been coated with a special enamel that partly cleans itself. This does not stop all marks on the lining, but helps to reduce the amount of manual cleaning needed.

These panels work better above 200 °C. If you do most of your cooking below this temperature, occasionally remove the panels and wipe with a lint free cloth and hot soapy water. The panels should then be dried and replaced and the oven heated at 200 °C for about one hour. This will ensure that the panels are working effectively.

Removing the Panels to clean the Enamel Interior

If you wish to clean the enamel interior of the oven, you will need to remove the shelves, followed by the 'Cook & Clean' panels. Each side of the oven is fixed with four fixing screws. You do not have to remove the screws to remove the oven panels. Simply lift each side panel upwards, slide them off the screws and then pull them forwards (**Fig.5-8**).

Once the panels have been removed, the oven enamel interior can be cleaned.

DO NOT use steel wool, oven cleaning pads, or any other materials that will scratch the surface.

The Tall Oven

To clean the oven sides, slide out the shelves, unhook the supports from the oven sides and lift out (**Fig.5-9**).

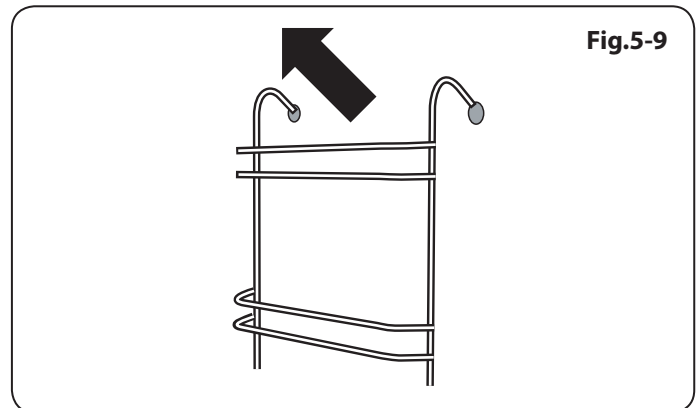
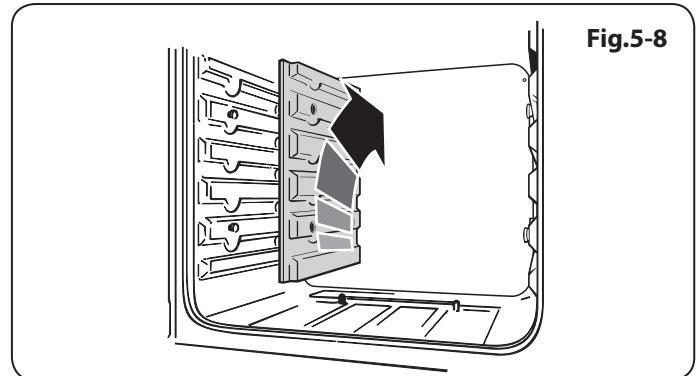
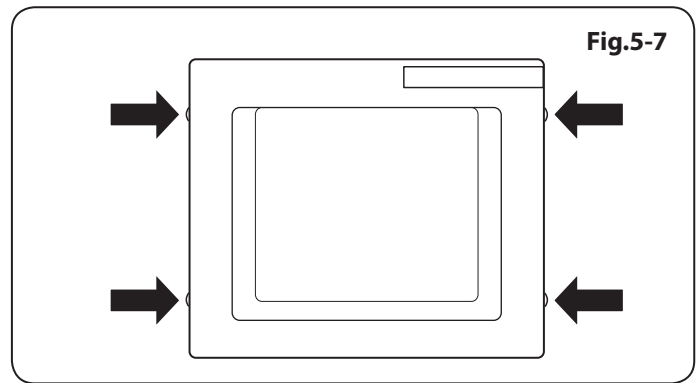

Cleaning Table

Cleaners listed are available from supermarkets or electrical retailers as stated. For enamelled surfaces use a cleaner that is approved for use on vitreous enamel.

Regular cleaning is recommended. For easier cleaning, wipe up any spillages immediately.

Hotplate		
Part	Finish	Recommended Cleaning Method
Hob Top	Enamel or stainless steel	Hot soapy water, soft cloth. Any stubborn stains remove gently with a nylon scourer.
Electric Sealed Hob Plate	Cast iron	Remove rust and food debris with a well soaped steel wool pad along the grain. Rinse and allow to dry. Apply a proprietary hotplate restorer (Electrical Retailers) to restore colour and protect the plates.
Ceramic/Induction hob	Toughened glass	Hot soapy water; cream cleaner/scourer if necessary.
Griddle Plate (some models only)	Non-stick surface	Allow to cool. Wash in hot soapy water. Do not use abrasive cleaners/scourers. Dishwasher.
Warming Zone (some models only)	Toughened glass	Hot soapy water, cream cleaner/scourer if necessary.
Outside of cooker		
Part	Finish	Recommended Cleaning Method
Door, Door surround and Storage Drawer exterior.	Enamel or paint	Hot soapy water, soft cloth. Any stubborn stains, remove gently with a liquid detergent.
	Stainless steel	E cloth or microfibre all-purpose cloth (supermarket)
Sides and plinth	Painted surface	Hot soapy water, soft cloth.
Splashback/rear grille	Enamel or stainless steel	Hot soapy water, soft cloth. Cream cleaner, with care, if necessary.
Control panel	Paint, enamel or stainless steel	Warm soapy water. Do not use abrasive cleaners on lettering.
Control knobs/handles & trims	Plastic/chrome, copper or lacquered brass	Warm soapy water, soft cloth.
	Brass	Brass polish.
Oven Door Glass/Glass Lid	Toughened glass	Hot soapy water, cream cleaner/scourer if necessary.
Oven and Grill		
Part	Finish	Recommended Cleaning Method
Sides, floor & roof of oven NOT COOK & CLEAN OVEN PANELS (see below)	Enamel	Any proprietary oven cleaner that is suitable for enamel. CAUTION: CORROSIVE/CAUSTIC OVEN CLEANERS: FOLLOW MANUFACTURERS INSTRUCTIONS. Do not allow contact with the oven elements.
Cook & Clean Oven Panels (some models only)	Special enamel that partly cleans itself	This surface cleans itself at 200 °C and above, or the panels can be removed and washed with hot soapy water and a nylon brush (see 'The Ovens' in 'Cleaning your cooker').
Oven Shelves, Handyrack, Grill Trivet, Handygrill rack	Chrome	An oven interior cleaner that is suitable for chrome. Soap filled pad. Dishwasher.
Grill Pan/Meat Tin (some models only)	Enamel	Hot soapy water. Soap filled pad. Dishwasher.

6. Troubleshooting

⚠ Interference with and repairs to the hob MUST NOT be carried out by unqualified persons. Do not try to repair the hob as this may result in injury and damage to the hob. Please arrange for repair by a suitably competent person.

Note: The induction hob is able to self-diagnose a number of problems and can show this information to the user via the hob control display. Error codes may be displayed if your hob has developed a fault.

If your appliance reports an error or is not working, you may be able to correct the fault by consulting the following.

Error code E2 is displayed

The electronic unit is too hot. Please check the installation of the cooker, making sure that there is sufficient ventilation. In extreme cases, if a cooking utensil has been allowed to boil dry this error code may also be displayed. If in doubt please contact your installer or a qualified repair engineer.

No display operation

Over voltage or loss of supply voltage to the cooker. If in doubt please contact your installer or a qualified repair engineer.

Error code ERxx or Ex is displayed

The appliance has developed an internal technical fault that cannot be rectified by the user. Please contact your installer or a qualified repair engineer.

The fuse blows or the RCD trips regularly

Please contact your installer or a qualified repair engineer.

The hob will not switch on

Has the wiring system in the house blown a fuse or tripped an RCD?

Has the hob been correctly connected to the mains supply?

Has the child lock been activated? Please refer to the child lock section for details of this function.

The induction hob is noisy

When using the induction hob there may be some 'noise' emitted from the pan. This is normal and may be most noticeable when cooking on high power settings or if 5 pans are used simultaneously. The type of pan may also contribute to induction 'noise'.

The cooling fan

The induction hob incorporates a cooling fan. This cooling fan is active when either the grill or ovens are on. Under certain conditions, the cooling fan may remain active when the grill or ovens are switched off. This is normal and the fan will switch off automatically.

A crack has appeared in the hob surface

Disconnect the cooker immediately from the power supply and arrange for its repair. Do not use the cooker until after the repair.

My hob is scratched

Always use the cleaning methods recommended in this guide, and ensure that the pan bottoms are smooth and clean.

Marks from mineral deposits from water or food can be removed with a cleaning cream. However, tiny scratches are not removable but will become less visible in time as a result of cleaning.

The oven fan is noisy

The note of the oven fan may change as the oven heats up – this is perfectly normal.

Grill not cooking properly

Are you using the pan and trivet supplied with the cooker? Is the pan being used on the runners, not the floor of the compartment? Is the grill tray pushed back fully to the 'back stop' position?

The knobs get hot when I use the oven or grill. Can I avoid this?

Yes, this is caused by heat rising from the oven or the grill, and heating them up. Do not leave the oven door open. Make sure that the grill pan is pushed right back to the 'back stop' when grilling.

Always grill with the grill compartment door open.

If there is an installation problem and I don't get my original installer to come back to fix it, who pays?

You do. Service organisations will charge for their call-outs if they are correcting work carried out by your original installer. Therefore, it's in your own interest to keep track of this installer so that you can contact them as required.

Power failure

In the event of a failure in the electrical supply, remember to reset the clock to ensure that the timed oven continues to operate.

Fig.6-1

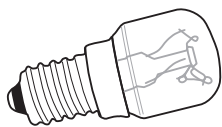
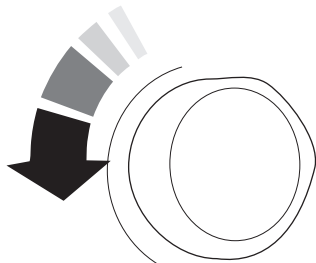

Fig.6-2



Food is cooking too slowly, too quickly, or burning

Cooking times may differ from your previous oven. Check that you are using the recommended temperatures and shelf positions – see the oven cooking guide. Then adjust the settings according to your own individual tastes.

The oven is not cooking evenly

Do not use a baking tray with dimensions larger than those specified in the section on 'General Oven Tips'.

If you are cooking a large item, be prepared to turn it round during cooking.

If two shelves are used, check that space has been left for the heat to circulate. When a baking tray is put into the oven, ensure that it is placed centrally on the shelf.

Check that the door seal is not damaged and that the door catch is adjusted so that the door is held firmly against the seal.

A dish of water when placed on the shelf should be the same depth all over. (For example, if it is deeper at the back, then the back of the cooker should be raised up or the front lowered.) If the cooker is not level, arrange for your supplier to level it for you.

The timed oven is not coming on when turned on manually

Is the power on? Is the clock illuminated? If not, there may be something wrong with the power supply. Is the cooker supply on at the isolator switch?

Has the time of day been set?

Is the key symbol (🔒) showing in the display to signify that the oven is locked? See the 'Clock' section of the instructions for more information on the key lock feature.

The timed oven is not coming on when automatic cooking

Has the oven knob been left in the OFF position by mistake? Is the oven locked (see above)?

Oven temperature getting hotter as the cooker gets older

If turning the temperature down using the oven control knob has not worked, or has only worked for a short time, then you may need a new thermostat. This should be fitted by a service person.

The oven light is not working

The bulb has probably blown. You can buy a replacement bulb (which is not covered under the guarantee) from most electrical stores. Ask for an Edison screw fitting 15 W 240 V lamp, FOR OVENS (**Fig.6-1**). It must be a special bulb, heat resistant to 300 °C. See the HELP leaflet for spares by mail order.

Before removing the existing bulb, turn off the power supply and make sure that the oven is cool. Open the oven door and remove the oven shelves.

Locate the bulb cover and unscrew it by turning it anti-clockwise - it may be very stiff (**Fig.6-2**).

Taking care to protect your fingers with a glove in case the bulb should shatter, unscrew the old bulb.

Screw in the new bulb clockwise and then screw the bulb cover back on. Turn on the electricity supply and check that the bulb now lights.

The oven door is misaligned

The bottom hinge of either oven door can be adjusted to alter the angle of the door (**Fig.6-3**). Loosen the bottom hinge fixing screws and use the notch and a flat bladed screwdriver to move the position of the hinge to set the hinge position (**Fig.6-4**).

Retighten the hinge screws.

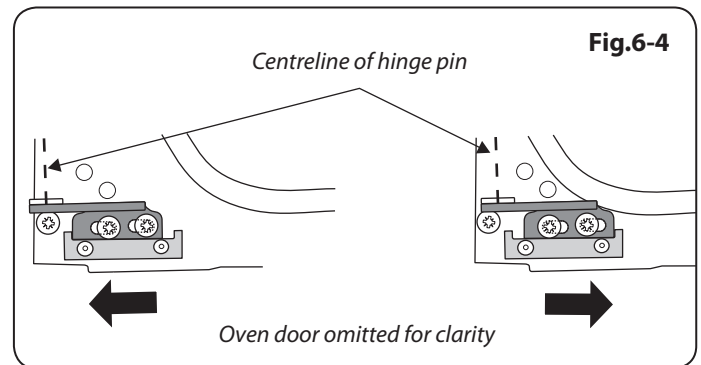
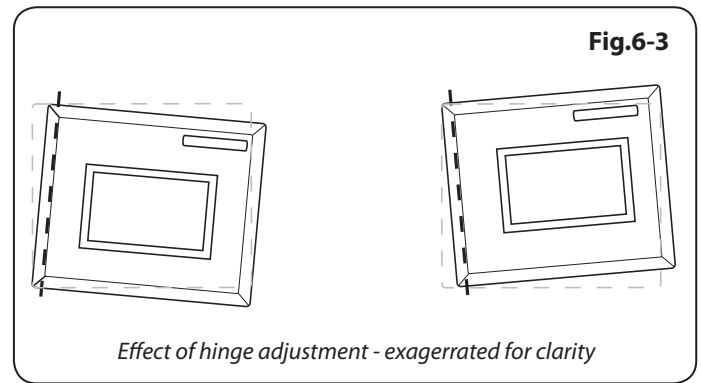

INSTALLATION

Check the appliance is electrically safe when you have finished.

7. Installation

Service and Spares

Firstly, please complete the appliance details below and keep them safe for future reference – this information will enable us to accurately identify the particular appliance and help us to help you. Filling this in now will save time and inconvenience if you later have a problem with the appliance. It may also be of benefit to keep your purchase receipt with this leaflet. You may be required to produce the receipt to validate a warranty field visit.

Retailer's Name and Address	Andi-Co Appliance Pty Ltd. 1 Stamford Road, Oakleigh, VIC 3166 Tel: (03) 9569 1225 Fax: (03) 9569 1450 Email: Service@andico.com.au
Name of Appliance	
Appliance Serial Number*	
Fuel Type	Induction Electric
Date of Purchase	
Installer's Name, Address and Telephone No.	
Date of Installation	

* This information is on the appliance data badge

If you have a problem

In the unlikely event that you have a problem with your appliance, please refer to rest of this booklet, especially the problem solving section, first to check that you are using the appliance correctly.

If you are still having difficulty, contact you retailer

Please note

If your appliance is outside the 12-month warranty period, our service provider may charge for this visit.

If you request an engineer to visit and the fault is not the responsibility of the manufacturer, our service provider reserves the right to make a charge.

Appointments not kept by you may be subject to a charge.

Out of Warranty

We recommend that our appliances are serviced regularly throughout their life to maintain the best performance and efficiency. The frequency of service will depend on usage – for normal usage once a year should suffice.

Service work should only be carried out by an suitably Authorised Person.

Spare Parts

To maintain optimum and safe performance, we recommend that only genuine spare parts are used. Do not use re-conditioned or unauthorised controls. Contact your retailer.

INSTALLATION

Check the appliance is electrically safe when you have finished.

Dear Installer



Before you start your installation, please complete the details below, so that, if your customer has a problem relating to your installation, they will be able to contact you easily.

Installer's Name
Installer's Company
Installer's Telephone number
Appliance Serial Number

You will also need the following tools:

1. Electric drill
2. Masonry drill bit (only required if fitting the cooker on a stone or concrete floor)
3. Wall plugs (only required if fitting the cooker on a stone or concrete floor)
4. Steel tape measure
5. Cross-head screwdriver
6. Flat-bladed screwdriver
7. Spirit level
8. Pencil
9. Adjustable spanner

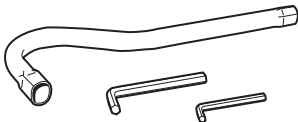
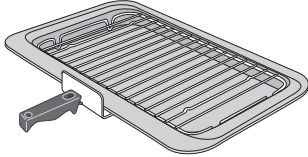
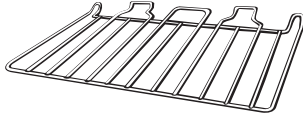
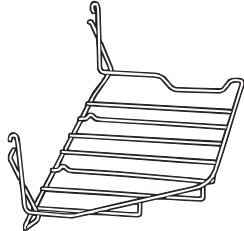
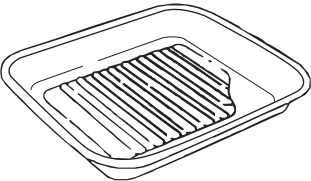
Checking the parts:

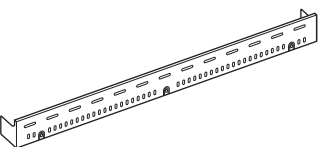
<i>Levelling tool and Allen keys</i>	<i>Grill pan and trivet (standard model shown)</i>
	
<i>2 main oven shelves</i>	<i>Handyrack</i>
	
<i>Roasting tin</i>	<i>Tall oven shelves & shelf supports</i>
	
<i>Plinth (standard model shown)</i>	
	

Safety Requirements

The cooker must be installed in a well-ventilated space, in accordance with the section entitled 'Electrical Connection'.

Read these instructions before installing or using the appliance.

Provision of Ventilation

This appliance is not connected to a combustion products evacuation device. Therefore, particular attention must be given to the relevant requirements regarding ventilation.

All rooms require a window that can be opened, or equivalent, while some rooms require a permanent vent in addition to the window.

Location of Cooker

The cooker may be installed in a kitchen/kitchen diner but NOT in a room containing a bath or shower.

This appliance is designed for domestic cooking only. Use for any other purpose could invalidate any warranty or liability claim.

You will need the following equipment to complete the cooker installation satisfactorily:

- Multimeter (for electrical checks)
- Cooker levelling tool with Allen keys (provided in pack)
- Stability bracket

INSTALLATION

Check the appliance is electrically safe when you have finished.

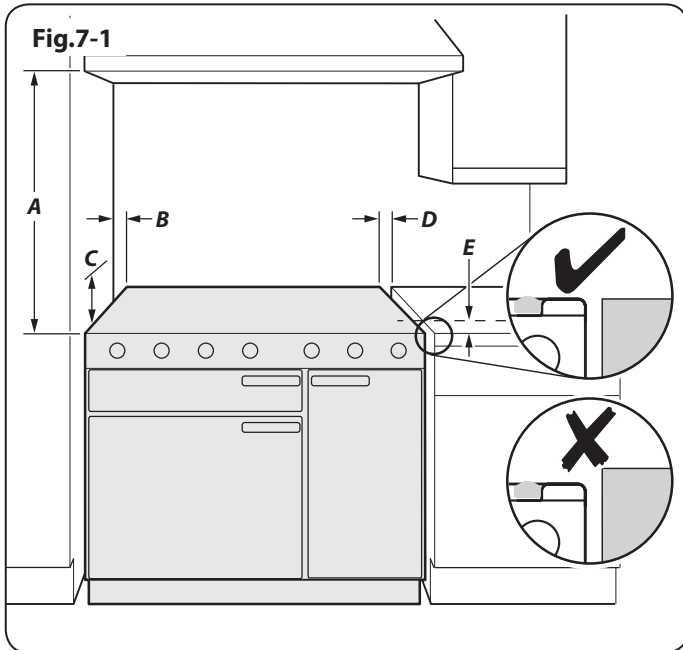

Positioning the Cooker

The diagram (**Fig.7-1**) shows the minimum recommended distance from the cooker to nearby surfaces as given in AS 5601 / AG 601.

1. Overhead – Measurement A

The minimum height of any surface above the cooker is 650 mm above the hotplate.

Range hoods and exhaust fans shall be installed in accordance with the manufacturer's instructions. However, in no case shall the clearance between the highest part of the hob of the cooking appliance and a range hood be less than 650 mm or, for an overhead exhaust fan, 750 mm.

2. Side Clearances – Measurements B & C

Where **B**, measured from the periphery of the nearest burner to any vertical combustible surface, or vertical combustible surface covered with toughened glass or sheet metal, is less than 200 mm, the surface shall be protected to ensure that the combustible surface does not exceed 65 °C above ambient*. Even with the surface protected, the dimension **B** should not be less than 135 mm above hotplate level.

The fixing of 5 mm thick ceramic tiles to the surface, or attaching fire resistant material to the surface and covering with sheet metal with a minimum thickness of 0.4 mm to a height **C of not less than 150 mm above the hotplate, should satisfy this requirement.*

3. Side Clearances – Measurement D & E

Where **D**, the distance from the periphery of the nearest burner to a horizontal combustible surface is less than 200 mm, then **E** shall be 10 mm or more, or the horizontal surface shall be above the trivet.

DO NOT place the cooker on a base.

A clearance of 130 mm is required if the cooker is near a corner of the kitchen, to allow the oven doors to open. The actual opening of the doors is slightly less, but this allows for some protection of your hand as you open the door.

We recommend a gap of 910 mm between units to allow for moving the cooker. Do not box the cooker in – it must still be possible to move the cooker in and out for cleaning and servicing.

INSTALLATION

Check the appliance is electrically safe when you have finished.

Moving the Cooker

- ⚠ **On no account try and move the cooker while it is plugged into the electricity supply.**
- ⚠ **The cooker is very heavy, so take great care.**
- ⚠ **DO NOT use the door handles or control knobs to manoeuvre the cooker.**

We recommend two people manoeuvre the cooker. Ensure that the floor covering is firmly fixed, or removed to prevent it being disturbed when moving the cooker around.

From the back tilt the cooker forward and remove the rear half of the polystyrene base pack (**Fig.7-2**). Repeat from the front and remove the front half of the poly base.

Now LOWER THE TWO REAR ROLLERS. First fit the levelling tool on the hexagonal adjusting nut, at both the front bottom corners of the cooker (**Fig.7-3**). Make 10 complete (360°) turns clockwise (**Fig.7-4**). (This means turning and removing the levelling tool 20 times.)

Completing the Move

Unfold the rear edge of the cardboard base tray. Open the grill door and right-hand oven door so that you can get a good grip on the bottom of the fascia panel as you move the cooker.

Grip under the fascia panel and lift the front of the cooker slightly (**Fig.7-5**).

- ⚠ **DO NOT use the door handles or control knobs to manoeuvre the cooker.**

Carefully push the cooker backwards off the pack base and remove the cardboard base tray. Position the cooker close to its final position, leaving just enough space to get behind it.

Levelling

It is recommended that you use a spirit level on a shelf in one of the ovens to check for level.

Place the cooker in its intended position, taking care not to twist it within the gap between the kitchen units as damage may occur to the cooker or the units.

The front feet and rear rollers can be adjusted to level the cooker. To adjust the height of the rear of the cooker use the levelling tool supplied to turn the adjusting nuts at the front bottom corners of the cooker. To set the front feet turn the bases to raise or lower.

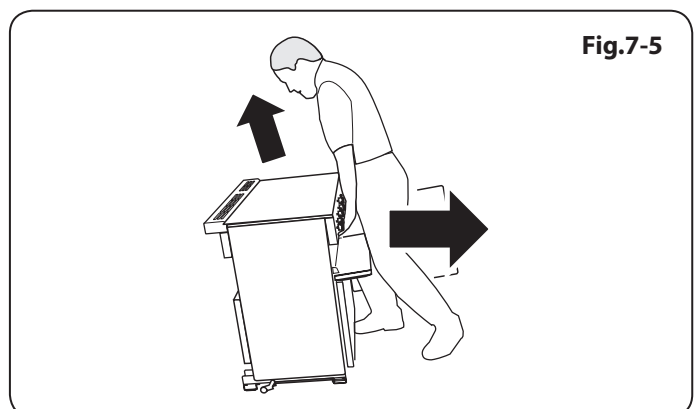
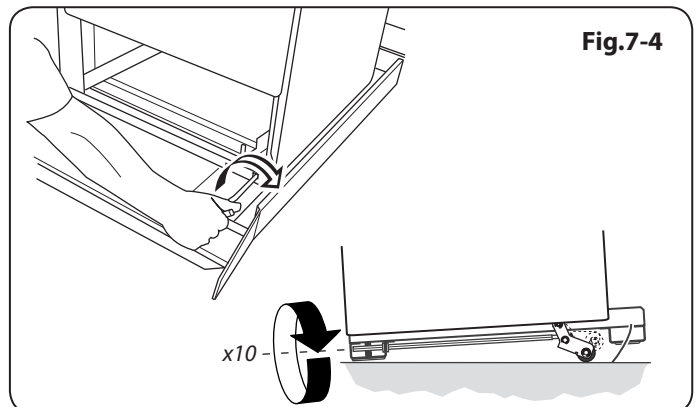
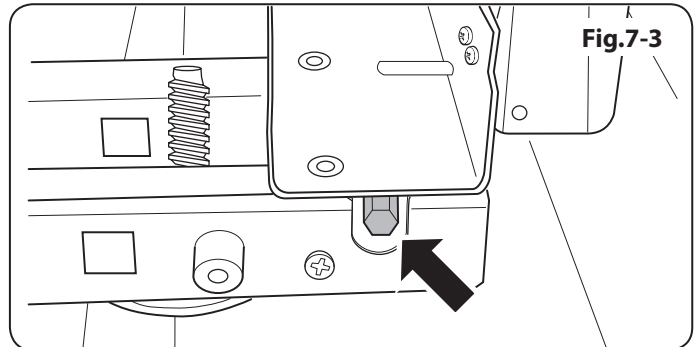
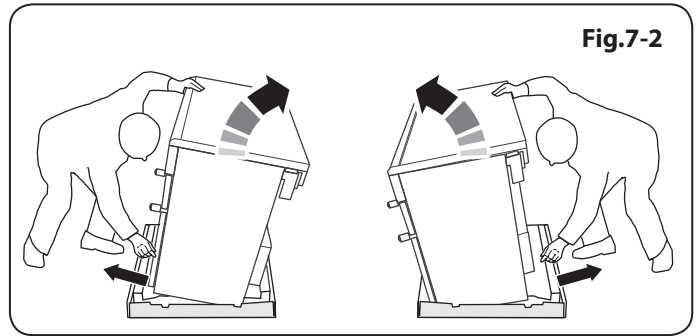

INSTALLATION

Check the appliance is electrically safe when you have finished.

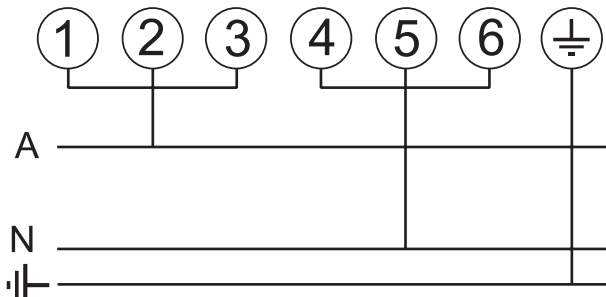

Fig.7-6 1-phase 240 V_{AC} 50 Hz

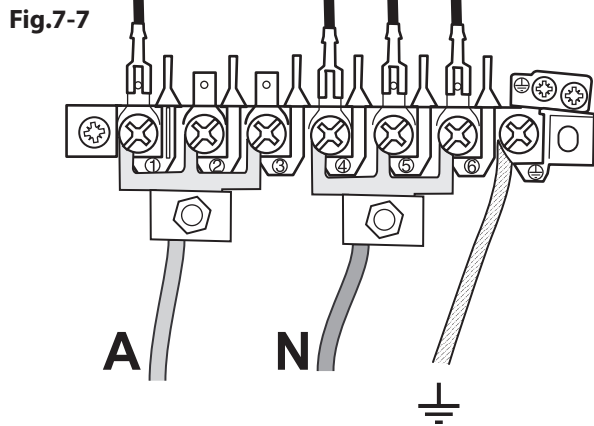

Fig.7-7

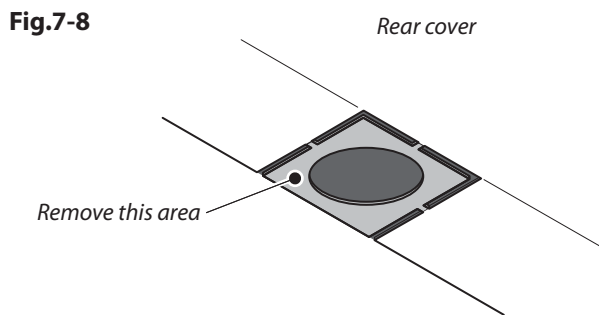

Fig.7-8

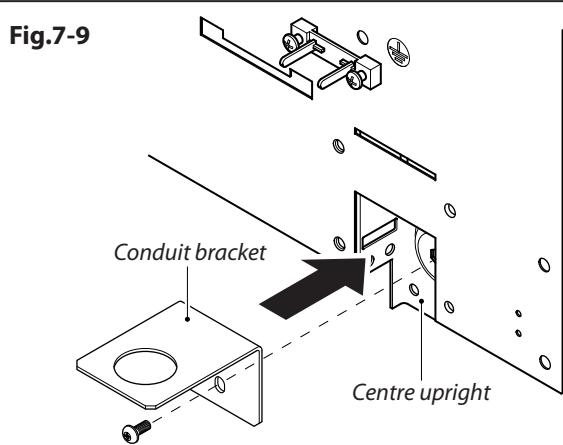

Fig.7-9

Electrical Connection

This appliance must be installed by a qualified electrician to comply with the relevant regulations (AS/NZS 60335.2.6:2002) and also the local electricity supply company requirements.

Ensure that the mains characteristics (voltage, nominal, power, etc.) match the ratings indicated on the data plate affixed to the cooker.

The cooker is preset for a single-phase earthed electrical connection. It is essential to install a multi-pole circuit breaker that completely disconnects the appliance from the mains, with a minimum contact break distance of 3 mm.

Current Operated Earth Leakage Breakers

The combined use of your induction cooker and other domestic appliances may cause nuisance tripping, so we recommend that the cooker is protected on an individual RCD (Residual Current Device) or RCBO (Residual Current Breaker with Overload).

IF IN DOUBT, PLEASE CONSULT A SUITABLY QUALIFIED ELECTRICIAN.

⚠ WARNING: THIS APPLIANCE MUST BE EARTHED

The appliance must be connected to an efficient earthing circuit. If the electricity network is not equipped with an earth connection, then it must be installed separately in compliance with local regulations.

Earthing is a safety measure required by law, and must be performed with particular care by a qualified technician, who must also check that the electricity supply characteristics are correct.

The total electrical load of the appliance is approximately 17 kW. The cable size used should be suitable for this load and comply with all local requirements (i.e. PVC Insulated cable IEC 60227 – code 53 for ordinary cables).

Access to the mains terminal is gained by removing the electrical terminal cover box on the back panel. Connect the mains cable to the correct terminals for your electrical supply type (**Fig.7-6** and **Fig.7-7**). Check that the links are correctly fitted and that the terminal screws are tight. Secure the mains cable using the cable clamp.

Fixed Wiring

For connection to fixed wiring, i.e. flexible conduit, remove the main rear cover.

Remove the electrical cable entry break out from the bottom of the rear cover (**Fig.7-8**).

Fix the conduit bracket to the centre upright (**Fig.7-9**). Fit the conduit up to the bracket and secure in place with the plastic nut.

Connect the mains cable to the correct terminals for your electrical supply type (**Fig.7-10** and **Fig.7-11**). Check that the links are correctly fitted and that the terminal screws are tight. Secure the mains cable using the cable clamp.

INSTALLATION

Check the appliance is electrically safe when you have finished.

Refit the rear cover.

Repositioning the Cooker following Connection

If you need to move the cooker once it has been connected, make sure it is switched off at the supply switch before gripping under the fascia panel and lifting the front of the cooker slightly (**Fig.7-5**). Check behind the cooker to ensure that the electricity cable is not caught. As you progress, always ensure that the cable has sufficient slack to allow the cooker to move.

Make sure to release the stability chain as you ease the cooker out. Do not forget to refit it when you replace the cooker.

When you replace the cooker, check behind it again once more to ensure that the electricity cable is not caught or trapped.

Hob Check

Check each cooking zone in turn. Be sure to use pans of the correct size and material.

Grill Check

Turn on the grill control and check that the grill heats up.

Oven Check

Set the clock as described earlier, and then turn on the ovens. Check the oven fans start to turn and that the ovens heat up.

Fitting the Handles and Handrail (Classic model only)

Remove the 4 mm Allen screws from the doors (**Fig.7-12**).

Fit the door handles and secure using the 4 mm screws (**Fig.7-13**).

⚠ The handles should be above the fixings.

Remove the 4 mm Allen screws from the top corners of the fascia (**Fig.7-14**). Fit the front handrail in position and secure using the 4 mm screws.

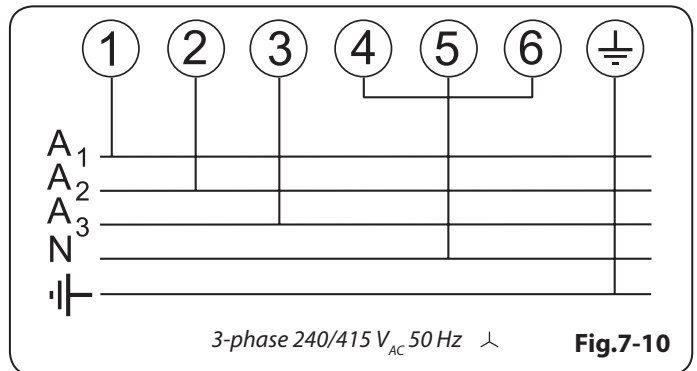

Fig.7-10

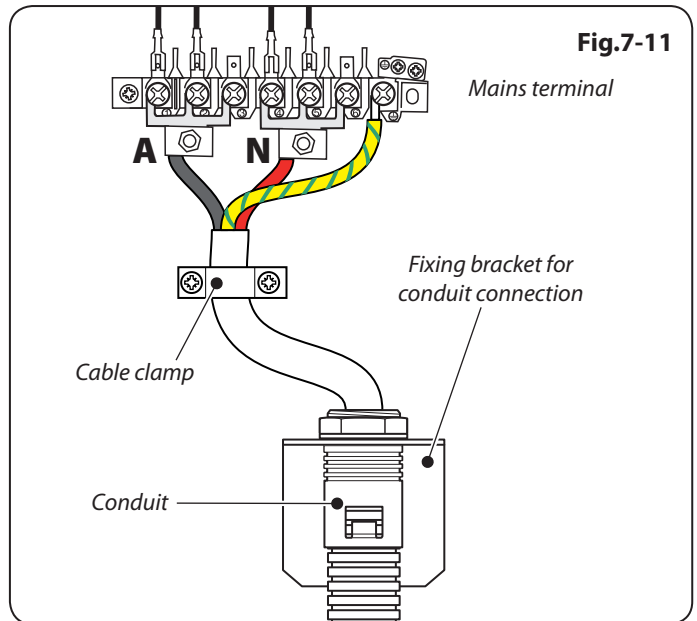
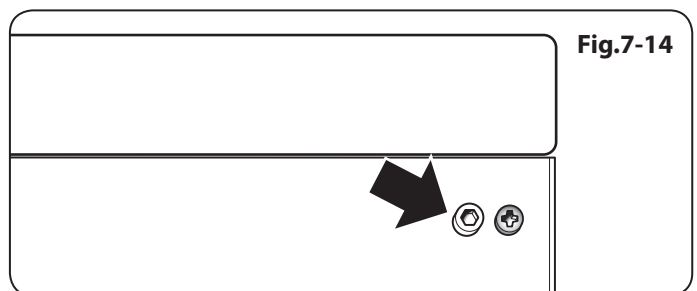
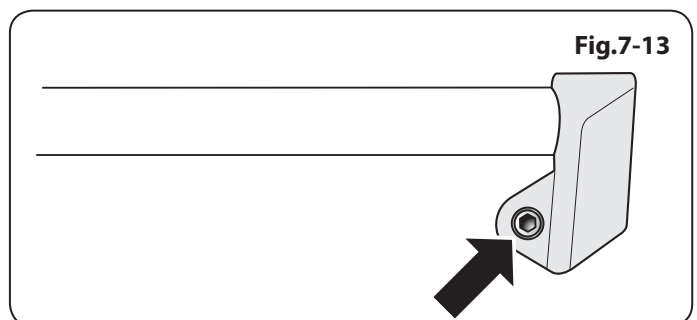
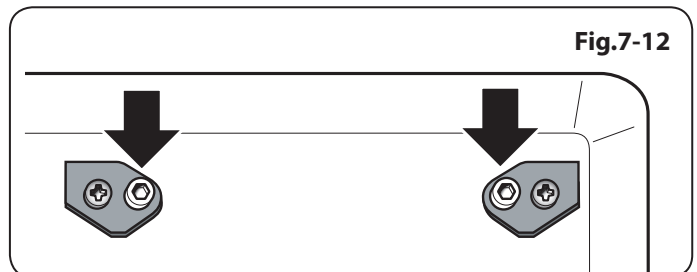

Fig.7-11



INSTALLATION

Check the appliance is electrically safe when you have finished.

Fig.7-15

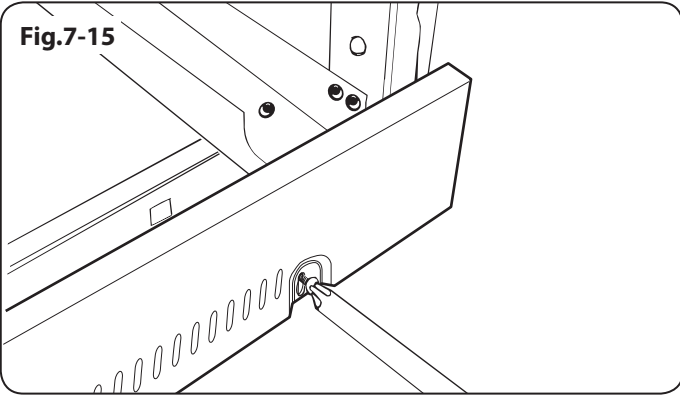

Fitting the Plinth

Classic & Professional+ models

Loosen the three screws along the front bottom edge of the cooker. Hook the central keyhole over the central screw. Twist and fit each end keyhole over their respective screws. Tighten the fixing screws (Fig.7-15).

Toledo model

Fit the inner plinth to the bottom front of the cooker using the 5 screws provided (Fig.7-16).

Fit the outer plinth (2 screws, 1 each end) to the inner plinth. The height of the outer plinth can be adjusted by sliding it up or down via the slotted hole (Fig.7-17).

Fig.7-16

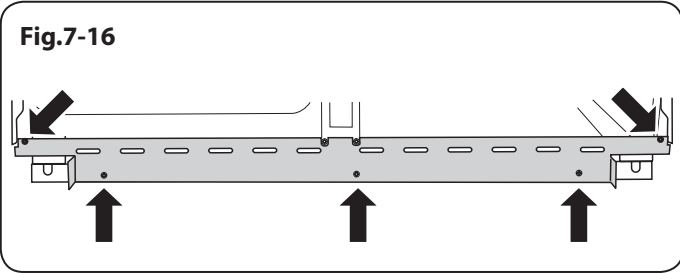

Fitting the Splashback (Classic model only)

The cooker can be installed with or without the supplied splashback.

Position the splashback on the rear of the hotplate and secure with the screws supplied (Fig.7-18).

Fig.7-17

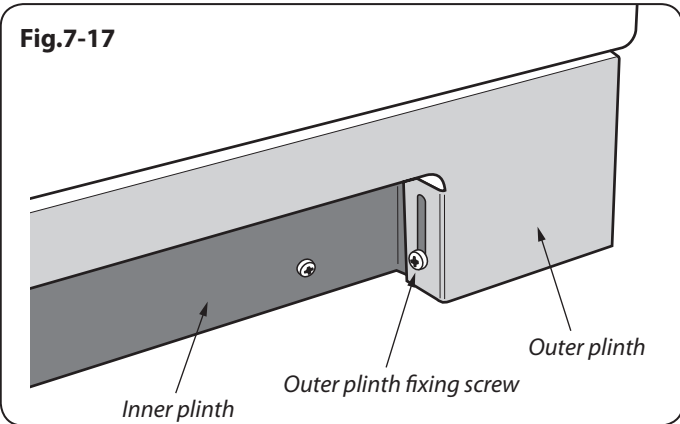

Customer Care

Installer: Please complete your details in this Guide, inform the user how to operate the cooker and hand over the instructions.

Thank you.

Fig.7-18

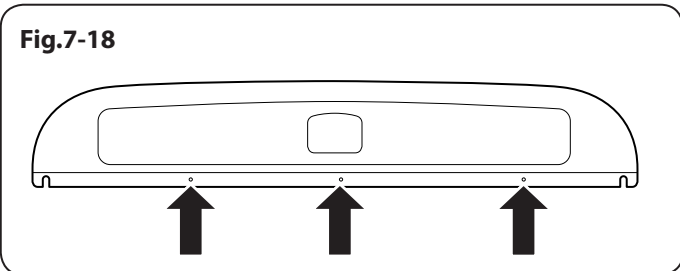

WARNING – SERVICING TO BE CARRIED OUT ONLY BY AN AUTHORISED PERSON
Disconnect from electricity before servicing. Check appliance is safe when you have finished.

8. Servicing

⚠ **Disconnect the cooker from the electricity supply before servicing, particularly before removing any of the following: control panel, side panels, ceramic hob, or any of the electrical components or cover boxes.**

⚠ **Before reconnection, check that the appliance is electrically safe.**

1. To Remove a Side Panel

Disconnect from electricity supply.

Pull the cooker forward. Pull off the control panel end caps at each end of the panel (**Fig.8-1**). Remove the fixing screws under the end caps.

Remove the retaining screws for each panel (one at the front, two at the rear, and one at each lower front corner of the side panels).

Reassemble in reverse order.

2. To Lift up the Ceramic Hob

Disconnect from electricity supply.

Pull off the push fit control panel end caps at each end and remove the end fixing screws under the end cap.

Remove the lower front retaining screws (one each side) situated beneath the lower edge at the front corners of the side panels.

Swing the side panels to gain access to the hob fixing screws (1 each side) at the top front of the side uprights.

Remove these screws.

Lift up the ceramic hob at the front and prop into position with a non-metallic prop.

CAUTION: The ceramic hob material is much more sensitive to scratches on the underside than the top.

Take care not to touch or scratch the underside of the ceramic as this will weaken the material and cause the top to shatter.

3. To Remove the Control Panel

Classic only: Remove the handrail by unscrewing the 2 end bracket fixing screws (**Fig.8-2**).

Pull off the control panel end caps at each end of the panel (**Fig.8-1**). Remove the fixing screws under the end caps.

Pull off all the control knobs. Open the grill and right-hand oven door and remove the control panel fixing screws underneath the control panel. The screws directly below the clock are for the clock fixing bracket, so do not remove them at this stage.

Lift the control panel, pull forward and disconnect the wiring from the rear.

Reassemble in reverse order. When replacing leads, refer to the wiring diagram in this manual. Check the operation of the timer.

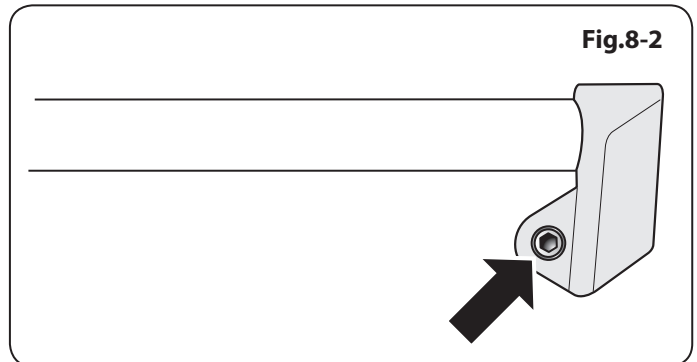
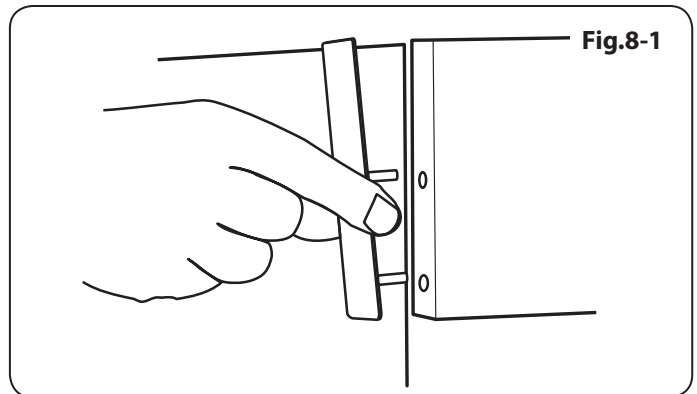

WARNING – SERVICING TO BE CARRIED OUT ONLY BY AN AUTHORISED PERSON
Disconnect from electricity before servicing. Check appliance is safe when you have finished.

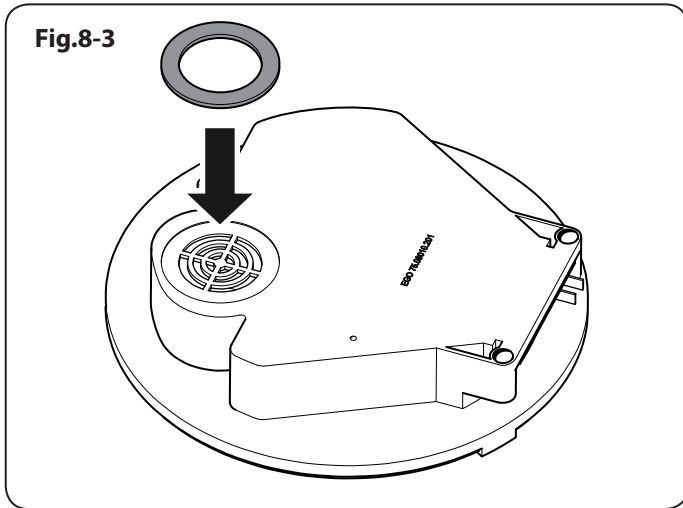

4. To Replace a Hob Element

Disconnect from electricity supply.

Lift up the ceramic hob (see 2). The Induction Heating Elements (IHE) are now accessible. Note the wire connection positions and element orientation for re-assembly. Disconnect the 4 wires, and remove the element unit and the 3 springs.

Fit the new sealing ring around the fan vent (**Fig.8-3**) and refit the 3 springs. Re-assemble in the reverse order.

Note: The IHE will require commissioning when the hob has been refitted.

5. To Replace the Light Switch

Disconnect from electricity supply.

Remove the control panel (see 3).

Note: The old switch may be destroyed during removal. Remove the old switch from its bezel by gripping the switch body behind the control panel and twisting sharply. Remove the switch bezel by folding back its locking wings and pushing forward. Fit the new bezel to the control panel by first lining up the raised key on its body with the cut-out in the control panel and pushing it in from the front.

Assemble the new switch to the bezel by lining up the key sections and pushing home. Fit the new button by pushing in from the front.

Replace the Control Panel in reverse order and test for correct operation.

6. To Remove the Electronic Timer

Disconnect from electricity supply.

Remove the control panel (see 3). Pull off the timer control button(s).

Remove the timer/mounting bracket assembly from the control panel by removing the fixing screws.

Remove the timer from its mounting bracket by depressing the plastic lugs on the timer case, at the same time pulling the unit forward.

Reassemble in reverse order. When replacing the leads, refer to the wiring diagram in this manual. Check the operation of the timer.

7. To Replace the Grill Controller

Disconnect from electricity supply.

Lift up the hob and remove the control panel (see 2 and 3). Disconnect the wiring from the controller. Remove the two screws holding the controller to the mounting panel. Fit the new controller and reassemble in reverse order. Check for correct operation.

8. To Remove a Grill Element

Disconnect from electricity supply.

Remove the grill pan from the grill compartment. Undo the two screws and washers in the grill roof and remove the enamelled front shield.

Undo the 2 screws and washers securing the grill element front support. Remove the screws from the grill elements.

Lift the elements out carefully and, noting their position, disconnect the leads from the element terminals.

WARNING – SERVICING TO BE CARRIED OUT ONLY BY AN AUTHORISED PERSON
Disconnect from electricity before servicing. Check appliance is safe when you have finished.

If it is not possible to disconnect the leads in this way, pull the cooker forward to gain access to the rear. Undo the screws securing the electric cover to the back sheet and remove the cover. Disconnect the terminals from the rear.

Fit new elements and reassemble in the reverse order. Check the operation of the grill.

9. To Remove the Grill Door

Remove the left-hand side panel (see 1). Remove the control panel (see 3). Remove the centre cover strip (5 screws, 2 top, 2 bottom, 1 in middle). Remove the two countersunk screws (1 each side) securing the grill hinge arms to the front of the grill chamber.

Note: The arms are spring tensioned. Carefully remove the grill door. Retain the gaskets.

Reassemble in reverse order, ensuring that the gasket is fitted between the hinge arm and the front of the grill chamber.

Remove the two screws and washers securing the grill element front support. Remove the screws from the grill element.

Lift the element out carefully, disconnecting the leads from the element terminals (noting their position). If it is not possible to disconnect the leads in this way, pull the cooker forward to gain access to the rear, remove the screws securing the electric cover to the back sheet, remove the cover and disconnect the terminals from the rear.

Fit the new element and reassemble in reverse order. Check the operation of the grill.

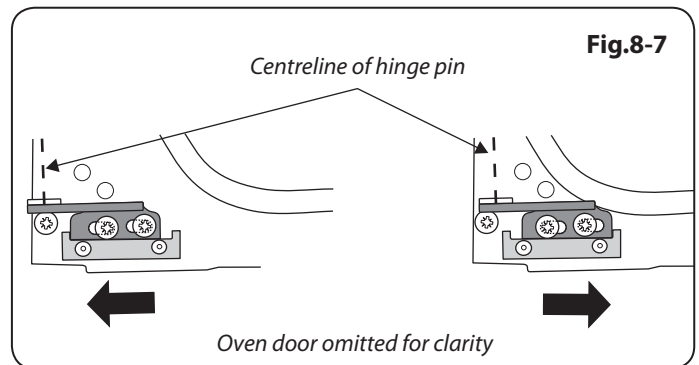
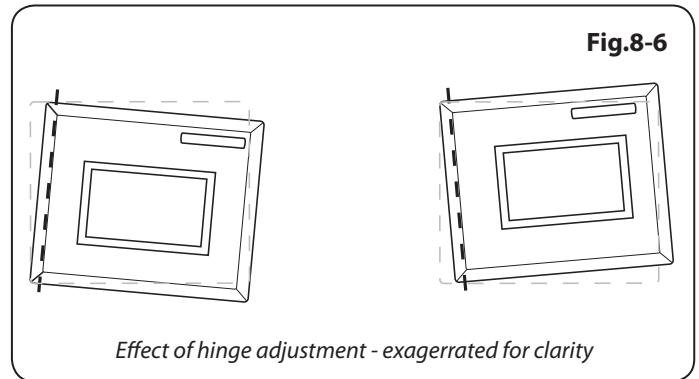
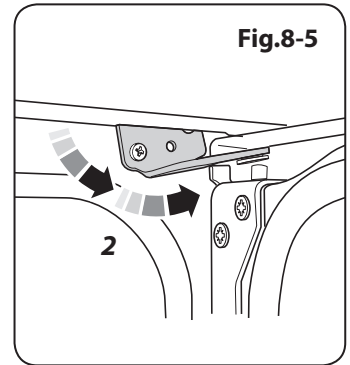
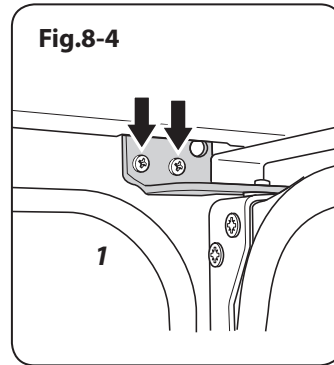

10. To Replace an Oven Door

Open the oven door. Support the door and remove the two screws securing the upper hinge and gasket to the cooker front (Fig.8-4). Remove the door from the lower hinge by lifting slightly and moving outwards (Fig.8-5).

⚠ The door is heavy, so take care.

Reassemble in reverse order.

11. To Adjust an Oven Door Angle

The bottom hinge of either oven door can be adjusted to alter the angle of the door (Fig.8-6). Loosen the bottom hinge fixing screws and use the notch and a flat bladed screwdriver to move the position of the hinge to set the hinge position (Fig.8-7).

Retighten the hinge screws.

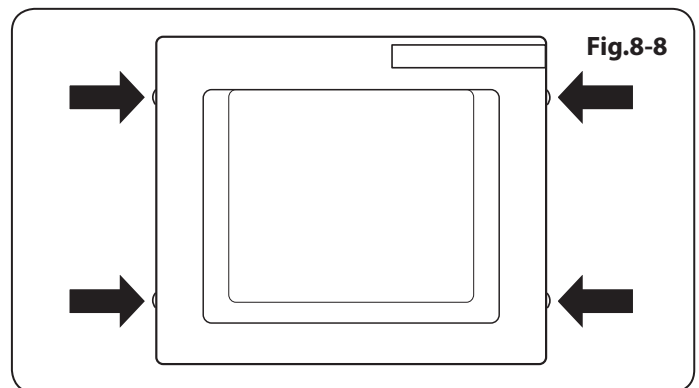

12. To Replace the Main Oven Door Outer Panel

Move the cooker forward to gain access to the sides.

Open the oven door slightly and remove the front panel fixing screws from the door sides – two each side (Fig.8-8).

Carefully lift off the outer door panel.

Remove the door handle from the panel by unscrewing the two retaining nuts. Fit the door handle to the new panel.

Fit the panel to the door. Reassemble in reverse order.

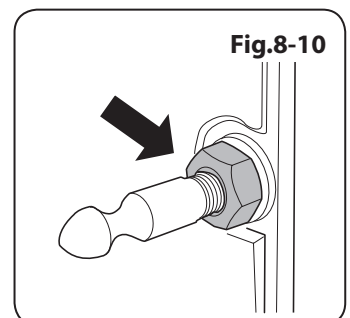
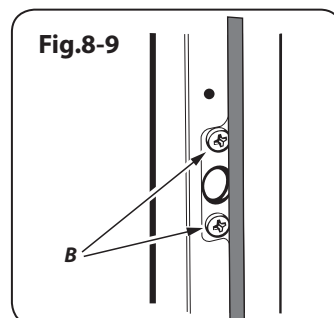

13. To Change the Main Oven Door Latch

Remove the outer door panel (see 12). Remove screws 'B' that hold the latch assembly to the inner door panel (Fig.8-9). Fit the new catch and reassemble in reverse order.

Verify the door operation.

WARNING – SERVICING TO BE CARRIED OUT ONLY BY AN AUTHORISED PERSON
Disconnect from electricity before servicing. Check appliance is safe when you have finished.

Fig.8-11

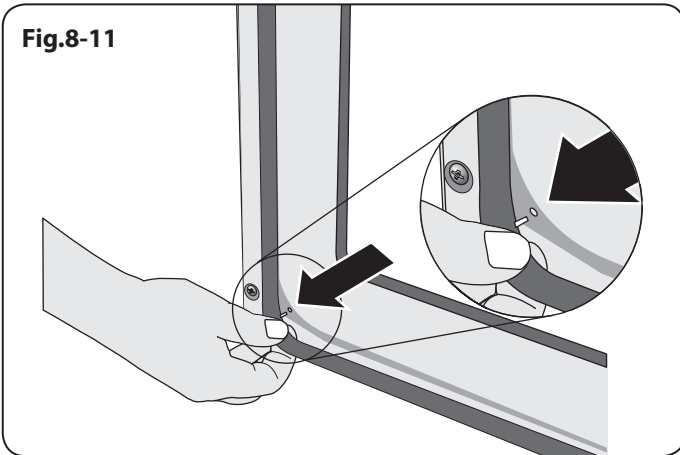

14. To Adjust the Main Oven Door Catch Keep

Open the oven door, and slacken off the locknut at the base of the keep (**Fig.8-10**).

Screw in or out as required until the required fit is obtained. Retighten the locking nut.

15. To Replace the Tall Oven Door Outer Panel

Remove the oven door (see 10). Lay the door face down on a suitable surface and remove the two screws from the bottom edge of the door and the two screws from the inside face of the door.

Remove the outer door panel. Remove the handle by unscrewing the two screws.

Unscrew the two cross-headed screws holding the door handle fixing bracket to the door panel. Fit the door handle bracket and door handle to the new panel.

Fit the panel to the door and reassemble in the reverse order.

16. To Replace the Tall oven Magnetic Latch

Remove the control panel (see 3). Remove the plinth and the central vertical cover (5 screws). Prise the retaining clip off the magnet unit.

Fit the new unit and retaining clip, and reassemble in reverse order. Check that the door operates correctly.

17. To Replace an Oven Door Seal

Open the oven door. The seal has small hooks that hold it in place by locating into holes in the rear door face on the main oven and oven front face on tall oven. At the corner, pull the seal diagonally away from the door centre until the hook is released (**Fig.8-11**). Proceed to the next hook and release it in a similar way, and so on.

You can use force if the hooks are stiff, as the old seal will be discarded.

Carefully lift away the inner back. Reassemble in reverse order making sure that the four screws and washers are fully tightened.

18. To Replace a Thermostat

Disconnect from the electricity supply.

Lift the ceramic hob and remove the control panel (see 2 & 3). Open the oven door. Remove the oven furniture.

For the right-hand oven, remove the thermostat phial cover (two screws). Unclip the thermostat phial from the clips in the oven back.

For the left-hand oven, pull cooker forward to gain access to the cover box at the rear of the cooker. Remove the four screws securing the cover and lift clear.

Feed the thermostat capillary out of the oven. Disconnect the wiring from the thermostat. Remove two screws holding thermostat to mounting panel. Fit new thermostat and reassemble in reverse order. Ensure that the phial is clipped to the oven back with the phial centrally positioned between the clips.

Check the operation of the thermostat.

WARNING – SERVICING TO BE CARRIED OUT ONLY BY AN AUTHORISED PERSON
Disconnect from electricity before servicing. Check appliance is safe when you have finished.

19. To Remove an Oven Element Thermal Cut-out

Disconnect from electricity supply.

Pull the cooker forward to gain access to the cover box. Undo the cover screws and lift clear. The cut-out is located on the earth plate beside the oven element connections. Disconnect the cut-out wiring. Undo the fixings that secure the cut-out to the earth plate and remove. Fit the replacement control and re-assemble in reverse order.

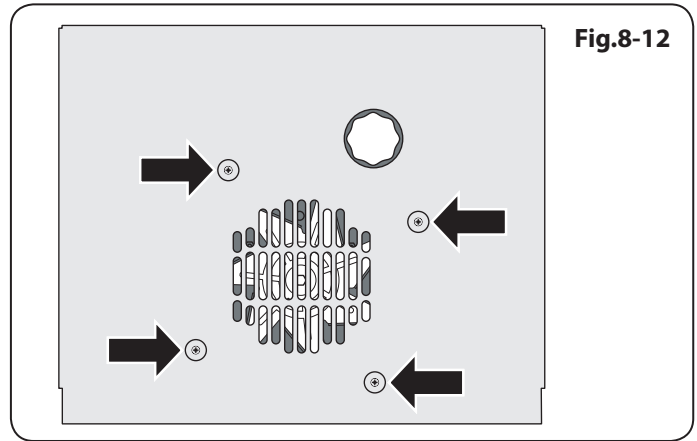

20. To Remove an Oven Inner Back

Disconnect from electricity supply.

Open the door and remove the shelves. Remove the screws and washers securing the inner back to the back of the oven (**Fig.8-12**). Carefully lift away the inner back. Reassemble in reverse order making sure that the screws and washers are fully tightened.

21. To Remove the Fan Oven Element

Disconnect from electricity supply.

Remove the oven inner back (see 20). Remove the two screws from the top of the element and the one from the bottom of the element inside the oven (**Fig.8-13**).

Lift the element out carefully, disconnecting the terminals connected to the element (noting their positions).

If it is not possible to disconnect the leads in this way, pull the cooker forward to gain access to the rear.

Remove the screws securing the electric cover to the back sheet, remove the cover and disconnect the terminals from the rear.

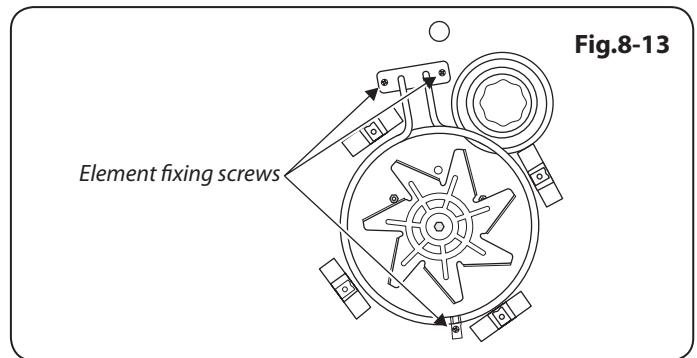

22. To Replace an Oven Fan

Disconnect from electricity supply.

Pull the cooker forward to gain access to the rear. Remove the screws securing the electric cover to the back sheet and remove the cover.

Disconnect the three terminals connected to the fan noting their position. Remove the oven inner back (see 20). Hold the fan blade and remove the centre nut (left-hand thread) two brass washers, fan blade and circlip. Unscrew the fan retaining nuts and washers (three off each) and lift the fan away from the rear of the cooker. Fit the new fan and reassemble in reverse order.

Check the operation of the oven.

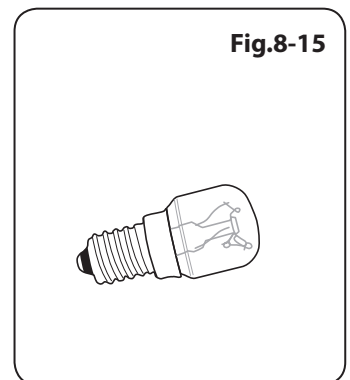
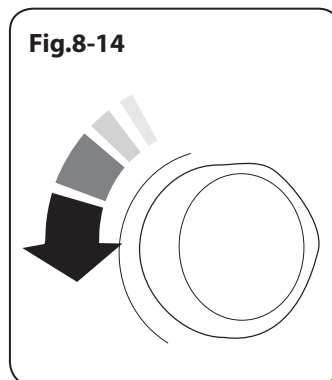

23. To Change Oven Light Bulb

Disconnect from electricity supply.

Make sure the oven is cool. Open the oven door and remove the oven shelves. Remove the grill pan and support from the grill chamber.

Unscrew the bulb cover by turning anticlockwise. It may be very stiff (**Fig.8-14**).

Taking care to protect your fingers in case the bulb should shatter, unscrew the old bulb.

Fit an Edison screw fitting 15 W 240 V lamp, FOR OVENS. It must be a special bulb, heat resistant to 300 °C (**Fig.8-15**).

Screw in the new bulb, and then screw back the bulb cover. Turn on the electricity supply and check that the bulb now lights.

9. Circuit Diagrams

Circuit Diagram: Hob

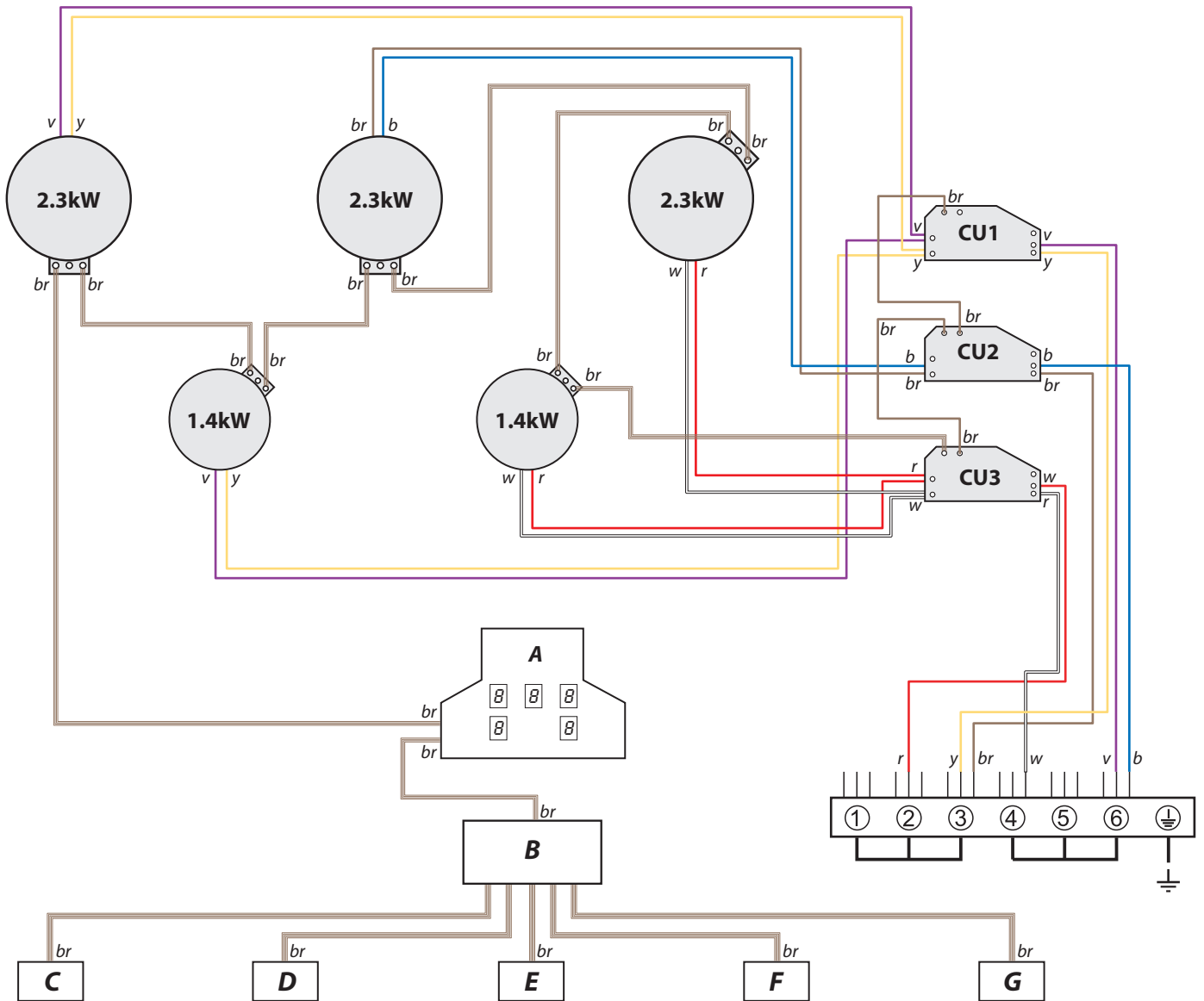

Code	Description
A	Touchlite panel
B	Distribution board
C	Left-hand front control
D	Left-hand rear control
E	Central control
F	Right-hand rear control
G	Right-hand front control
CU1	Left-hand pair (slave) control unit
CU2	Centre (slave) control unit
CU3	Right-hand pair (master) control unit

Colour Code	
b	Blue
br	Brown
bk	Black
or	Orange
r	Red
v	Violet
w	White
y	Yellow
g/y	Green/yellow
gr	Grey

Circuit Diagram: Fan Oven

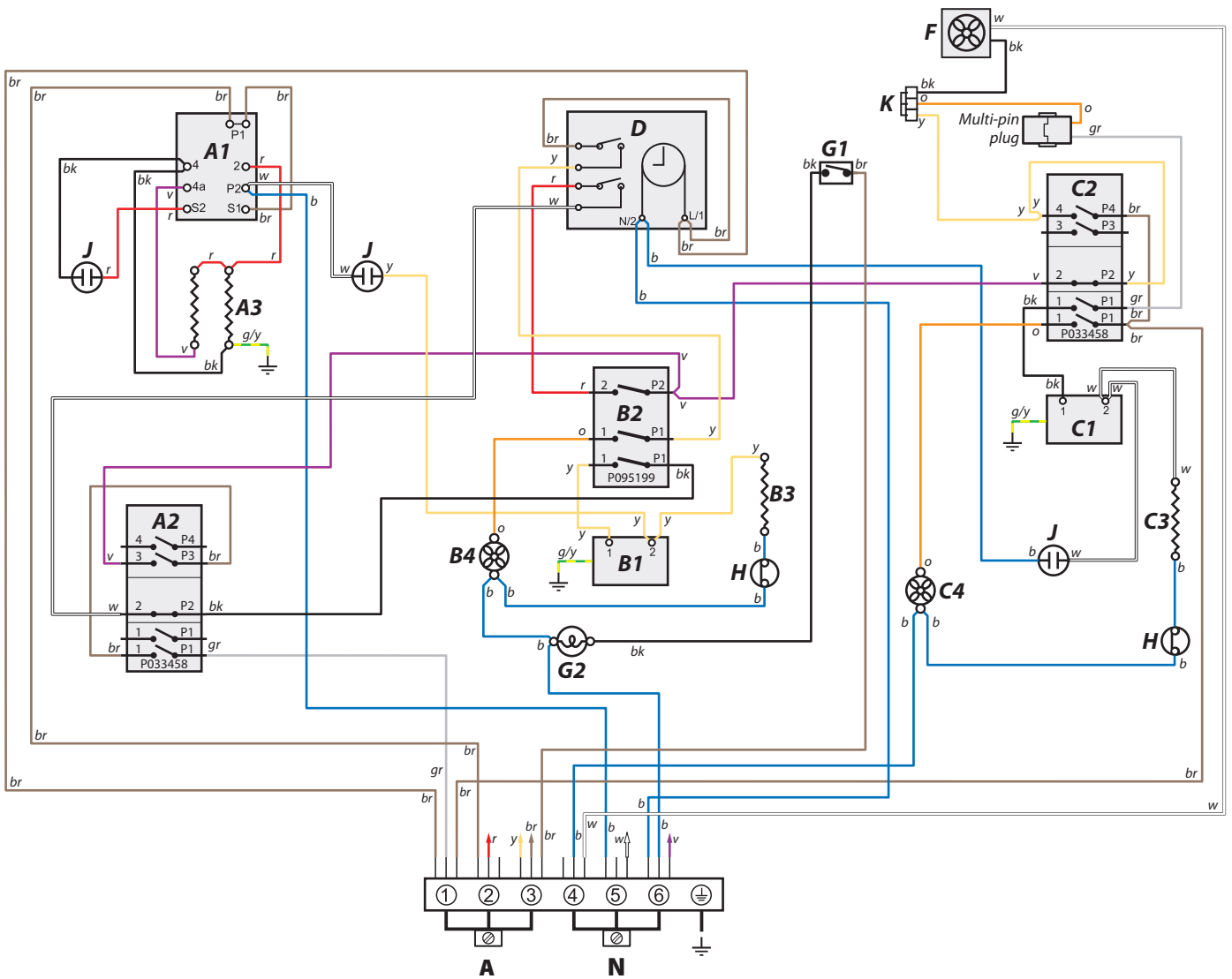

Key

The connections shown in the circuit diagram are for single-phase. The ratings are for 240 V 50 Hz.

Code	Description
A1	Grill energy regulator
A2	Grill front switch
A3	Grill elements
B1	Left-hand zoned oven thermostat
B2	Left-hand oven thermostat front switch
B3	Left-hand oven element
B4	Left-hand oven fan
C1	Right-hand oven thermostat
C2	Right-hand oven thermostat front switch

Code	Description
C3	Right-hand oven element
C4	Right-hand oven fan
D	Clock
F	Cooling fan
G1	Oven light switch
G2	Oven light
H	Thermal cut-out
J	Neon
K	Connection block

Colour Code	
b	Blue
br	Brown
bk	Black
or	Orange
r	Red
v	Violet
w	White
y	Yellow
g/y	Green/yellow
gr	Grey

10. Technical Data

INSTALLER: Please leave these instructions with the user.

DATA BADGE LOCATION: Cooker back, serial number repeater badge below oven door opening.

Connections

Electric	230-240 V 50 Hz
-----------------	-----------------

Dimensions

Overall height	minimum 905 mm	maximum 930 mm
Overall width	900 mm	
Overall depth	602 mm (to fascia inc. splashback); 610 mm (over hotplate)	

Refer to 'Positioning the Cooker'.

Ratings

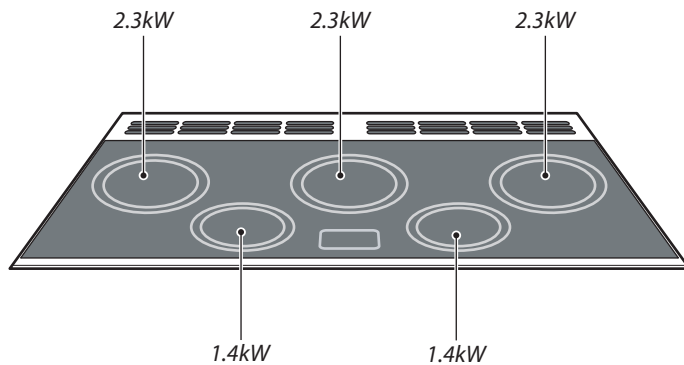

Ovens	Main oven	Tall oven
	Forced air convection	Forced air convection
	2.5 kW	2.5 kW
Energy efficiency class on a scale of A (more efficient) to G (less efficient)	A	A
Energy consumption based on standard load	0.85 kWh	0.99 kWh
Usable volume (litres)	67	66
Size	Large	Large
Time to cook standard load	38 minutes	49 minutes
Surface area of the grid	1400 cm ²	790 cm ²

Grill	2.3 kW
--------------	--------

Maximum total electrical load at 240 V: 17.1 kW (approximate total including oven lights, oven fan, etc.)